

**Modicon**  
Lexium 17S Series SERCOS Servo Drive  
User Guide

890 USE 121 00 Eng

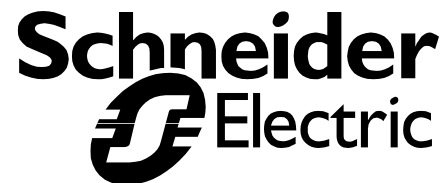



**Preface**

The data and illustrations found in this book are not binding. We reserve the right to modify our products in line with our policy of continuous product development. The information in this document is subject to change without notice and should not be construed as a commitment by Schneider Electric.

Schneider Electric assumes no responsibility for any errors that may appear in this document. If you have any suggestions for improvements or amendments or have found errors in this publication, please notify us.

No part of this document may be reproduced in any form or by any means, electronic or mechanical, including photocopying, without express written permission of the Publisher, Schneider Electric.

**CAUTION!**

All pertinent state, regional, and local safety regulations must be observed when installing and using this product. For reasons of safety and to assure compliance with documented system data, repairs to components should be performed only by the manufacturer.

**Failure to observe this precaution can result in injury or equipment damage.**

MODSOFT® is a registered trademark of Schneider Electric.

(SERCOS® interface is a trademark of SERCOS Interface, Inc., promotion society.)

The following are trademarks of Schneider Electric:

Modbus Modbus Plus Modicon Quantum 984 Concept

IBM® and IBM AT® are registered trademarks of International Business Machines Corporation.

Microsoft®, MS-DOS®, Windows®, Windows 95®, Windows 98® and Windows NT® are registered trademarks of Microsoft Corporation.

©Copyright 2001, Schneider Electric



---

# Contents

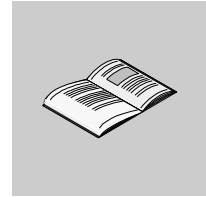

---

## Chapter 1 Introduction

At a Glance .....	1
Document Scope .....	1
What's in this Chapter .....	1
About this User Guide .....	2
Who Should Use this User Guide .....	2
How this User Guide Is Organized .....	2
Related System Components .....	4
SERCOS Multi-Axis Motion Control System .....	4
UniLink Commissioning Software for 17S .....	4
Related Documentation .....	5
Documents .....	5
Hazards, Warnings and Guidelines .....	6
Hazards and Warnings .....	6
Additional Safety Guidelines .....	9
Qualified Personnel .....	9
Standards and Compliances .....	10
European Directives and Standards .....	10
EC Directive Compliance .....	10
SERCOS Standard .....	11
UL and cUL Compliance .....	11
Conventions .....	12
Acronyms and Abbreviations .....	12

## Chapter 2 Product Overview

At a Glance.....	15
Introduction .....	15
What's in this Chapter .....	15
The 17S Series SERCOS Drive Family .....	16
Introducing the 17S SERCOS Drive Family .....	16
Drives Available .....	16
Implementing the Drives .....	16
Applicable Servo Motor Types .....	16
Electrical Considerations .....	17
17S Drive Family Portrait .....	18
17S Drives Front View .....	19
Equipment Supplied .....	20
Equipment Available .....	20
17S System Configuration Diagram .....	21
Modicon Multi-Axis Motion SERCOS Network Configuration .....	22
Overview .....	22
Which Motion Controllers run a SERCOS Network .....	22
SERCOS Fiber- Optic Transmit and Receive Connectors .....	22
Example of a Typical SERCOS Network Ring Configuration .....	23
Benefits of Fiber-Optic Communication .....	24
Two Types of Fiber-Optic Communication .....	24
Digital Control .....	25
Usability Enhancements .....	26
Overview of 17S Internal Electronics .....	27
17S Internal Electronics Block Diagram .....	27
General Characteristics .....	28
Primary Power .....	28
Bias Power .....	28
EMI Suppression .....	28
Internal Power Section .....	29
DC Link Capacitor Reconditioning .....	29
Integrated Safe Electrical Separation .....	29
Keypad .....	29
LED Display and Discrete Indicators .....	30
Overview of System Software .....	31
Setup .....	31
Setting Parameters .....	31
Default Settings .....	31
UniLink Commissioning Software .....	32

## Chapter 3 Mounting and Physical Dimensions

At a Glance.....	33
What's in this Chapter .....	33
Installation Safety Precautions .....	34
Power Supply Overcurrent Protection .....	36
Earth Connections .....	36
Cable Separation .....	36
Air Flow .....	36
Drive Mounting and Physical Dimensions .....	37
17S Height, Width and Depth Dimensions .....	37
17S Drive and Mounting Area Dimensions .....	38
Optional External Regen Resistor Assembly Dimensions .....	39
Optional Motor Choke Assembly Dimensions .....	40

## Chapter 4 Wiring and I/O

At a Glance.....	41
Introduction .....	41
What's in this Chapter .....	42
Wiring and I/O Initial Considerations .....	43
Initial Considerations .....	43
Grounding .....	43
Wiring Overview .....	44
Overview of 17S Wiring Connections .....	44
Cable Shield Connections .....	47
Connecting Cable Shields to the Front Panel .....	47
Cable Shield Connection Diagram .....	48
Power Wiring .....	49
AC Mains Power Supply Connection .....	49
Bias Supply Connection .....	49
Serial Power Connections .....	50
Optional External Regen Resistor Connection .....	51
Regen Circuit Functional Description.....	51
Lexium BPH Servo Motor Connection (excluded BPH055) .....	52
Lexium BPH 055 Servo Motor Connection .....	53
Servo Motor (with Optional Dynamic Brake .....	
Resistors and Contactor) Connection .....	54
Servo Motor Holding-Brake Control Functional Description .....	55

Signal Wiring .....	57
Lexium BPH Resolver Connection (excluded BPH055) .....	57
Lexium BPH055 Resolver Connection .....	58
Encoder Input Connection .....	59
Auxiliary Encoder Interface .....	60
Analog Input Connection .....	63
Analog Inputs .....	63
Fault Relay and Digital I/O Connection .....	64
Digital Inputs and Outputs .....	64
Using Functions Pre-programmed into the Drive .....	65
Serial Communications Connection .....	66
RS-232 Null Modem Type Communication Connection Diagram .....	66

## Chapter 5 System Operation

At a Glance.....	67
What's in this Chapter .....	67
Powering Up and Powering Down the System .....	68
Power-on and Power-off Characteristics .....	68
Stop Function .....	69
Emergency Stop strategies .....	69
Wiring example .....	70
Procedure for Verifying System Operation .....	71
Overview .....	71
Quick Tuning Procedure .....	71
Front Panel Controls and Indicators .....	73
Keypad Operation .....	73
LED Display .....	73
SERCOS Communication LED Indicators .....	74



---

## Chapter 6 Troubleshooting

At a Glance.....	75
What's in this Chapter .....	75
Warning Messages .....	76
Warning Identification and Description .....	76
Error Messages .....	77
Error Identification and Description .....	77
Troubleshooting.....	81
Problems, Possible Causes and Corrective Actions.....	81

## Appendix A Specifications

At a Glance.....	83
What's in this Appendix .....	83
Performance Specifications.....	84
Performance Specifications Table .....	84
Environmental and Mechanical Specifications .....	85
Environmental Specifications Table.....	85
Mechanical Specifications Table .....	86
Electrical Specifications.....	87
What's in this Section .....	87
Electrical Specifications - Power .....	88
Line Input Specifications Table .....	88
Bias Input Specifications Table .....	89
External Fuse Specifications Table .....	89
Motor Output Specifications Table .....	90
Internal Power Dissipation Specifications Table.....	91
Electrical Specifications - Regen Resistor .....	92
Regen Circuit Specifications .....	92
Electrical Specifications - Signal .....	93
Motor Overtemperature Input Specifications Table .....	93
Resolver Input Specifications Table .....	93
Encoder Input Specifications Table .....	94
Emulated Encoder Output (Incremental Format) Specifications Table.....	94
Encoder Output (Incremental Format) Timing Diagram .....	95

Auxiliary Incremental Encoder Input Specifications Table .....	95
Discrete Input Specifications Table .....	96
Discrete Output Specifications Table .....	96
Fault Relay Output Specifications Table .....	97
Brake Output Specifications Table .....	97
Analog Input Specifications Table .....	98
Serial Communications Specifications Table .....	98
Wire Specifications .....	99

## Appendix B Parts List

At a Glance.....	101
What's in this Appendix .....	101
Lexium 17S Drives .....	102
Drives Available .....	102
External 24Vdc supply .....	103
External 24Vdc supply .....	103
Drive Cables .....	104
Drive to Motor Cables .....	104
RS-232 Serial Communications Cable Part Table .....	104
Encoder Output Cable Parts Table .....	104
Fiber Optic Cables Parts Table .....	105
Optional External Regen Resistor Assemblies .....	106
Optional Regen Resistor Assembly Part Table .....	106
Optional Motor Choke .....	107
Optional Motor Choke Part Table .....	107
Spare Parts .....	108
Spare Parts Table.....	108

## Appendix C Cable Connection Wiring Diagrams

At a Glance.....	109
What's in this Appendix .....	109
Wiring a Sub-D Connector with Shielding .....	110
Wiring the Sub-D Connector.....	110
Sub-D Connector Diagram .....	111
Wiring the Motor Power Connector (Drive end) .....	112

---

Wiring the Motor Power Connector .....	112
Motor Power Connector (Drive end) Diagram (excluded BPH055) .....	113
BPH055 Motor Power Connector (Drive end) Diagram .....	114
Serial Communication Interface Connection (X6) .....	115
Serial Communication Interface Cable Connectors .....	115

## **Appendix C Servo Loop Diagrams**

At a Glance.....	117
What's in this Appendix .....	117
17S Current Controller Overview .....	118
17S Current Controller Diagram .....	118
17S Velocity Controller Loop .....	119
17S Velocity Controller Loop Diagram .....	119
17S Position Controller Loop .....	120
17S Position Controller Loop Diagram.....	120

## **Appendix D Optional External Regen Resistor Sizing**

At a Glance.....	121
What's in this Appendix.....	121
Overview .....	122
Determining When Energy Is Absorbed .....	122
Determining Optional External Regen Resistor Size .....	123
Power Dissipation Calculation .....	123
Drive Energy Absorption Capability .....	124
Example Regen Resistor Power Dissipation Calculation .....	125
Example Motor and Drive Specifications .....	125
Example Step 1.....	126
Example Step 2 .....	127
Example Step 3 .....	127
Example Step 4 .....	128
Example Step 5 .....	128
Example Step 6.....	128
Example Step 7 .....	128
Example Step 8 .....	129



---

# Introduction



# 1

---

## At a Glance

**Document Scope** This user guide contains complete installation, wiring interconnection, power application, test and maintenance information on the Lexium 17S series SERCOS drive.

**What's in this Chapter** This chapter provides general information about this user guide and contains the following topics:

Topic	Page
About this user guide	2
Related system components and standards	4
Related documentation	5
Hazards, warnings, and guidelines	6
Standards and compliances	10
Conventions	12

---

## About this User Guide

---

### Who Should Use this User Guide

This user guide is written for any qualified person at your site who is responsible for installing (mounting and interconnecting), operating, testing and maintaining your Lexium 17S SERCOS drive and the servo system equipment with which it interfaces. In addition, the following precautions are advised:

- Transportation of the drive to, or from, an installation site should only be performed by personnel knowledgeable in handling electrostatically sensitive components.
- Commissioning of the equipment should only be performed by personnel having extensive knowledge of, and experience with, electrical and drive technologies.

You are expected to have some overall understanding of what your 17S SERCOS drive does and how it will function in a high-performance, multi-axis motion control system. Accordingly, be sure you read and understand the general information, detailed descriptions and associated procedures presented in this manual, as well as those provided in other relevant manuals, before installing your 17S. (See *Related System Components* later in this chapter.)

If you have questions, please consult your Schneider Electric customer representative.

---

### How this User Guide Is Organized

This manual is organized as follows.

Chapter/Appendix	Description
Chapter 1 <i>About this User Guide</i>	An introduction to this manual — who should use this manual, how this manual is organized, related publications, hazards and warnings.
Chapter 2 <i>Lexium 17S Product Overview</i>	General descriptions of the 17S SERCOS drives, descriptions of components that are supplied by Schneider in a typical 17S system, and a block diagram for internal electronics.
Chapter 3 <i>Mounting and Physical Dimensions</i>	Physical dimensions and information for mounting the 17S SERCOS drive, optional Regen resistor and (if required) optional servo motor choke.

---

*Continued on next page*

---

## About this User Guide, continued

---

### How this User Guide Is Organized, continued

Chapter/Appendix	Description
Chapter 4 <i>Wiring and I/O</i>	Wiring diagrams for the power connections and wiring diagrams and descriptions for all signal wiring connections — encoder, resolver, analog input, discrete I/O, fiber-optic and serial communications cable.
Chapter 5 <i>System Initialization, Commissioning and Operation</i>	Detailed procedures and associated descriptions on how to initialize, commission and operate a typical 17S system.
Chapter 6 <i>Troubleshooting</i>	Description of faults, probable causes and recommended corrective actions.
Appendix A <i>Specifications</i>	Specifications for the 17S SERCOS drives, including general, electrical, signal, and power specifications.
Appendix B <i>Parts List</i>	Part numbers related to the 17S SERCOS drive system.
Appendix C <i>Cable Connection Wiring Diagrams</i>	Procedures and associated diagrams that show how to wire Sub-D and power cable connectors as well as the serial communication cable used with the drive.
Appendix D <i>Servo Loop Diagrams</i>	Illustrations of several servo loops within the 17S SERCOS drive system.
Appendix E <i>Optional External Regen Resistor Sizing</i>	Description and procedure for determining the power dissipation requirement for the optional external Regen resistor.

---

---

## Related System Components

---

### **SERCOS Multi-Axis Motion Control System**

The 17S SERCOS drive is typically only one component in a larger, multi-axis motion control system. A multi-axis system is comprised of one motion controller and (depending on the controller) up to 32 drives. Each drive controls one servo motor.

---

### **UniLink Commissioning Software for 17S**

To configure your multi-axis system, you will be using the UniLink axis commissioning software, which Schneider supplies.

UniLink allows you to configure and tune your 17S axis quickly and easily. With its graphical user interface and oscilloscope tuning features, UniLink provides an easy point-and-click method for configuring motion setup parameters. UniLink minimizes or eliminates cumbersome programming tasks.

For complete information on UniLink, please see the UniLink online help.

---



---

## Related Documentation

---

### Documents

Related documentation that covers all these system components is illustrated below.

You will need these:

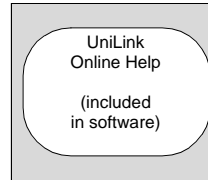

Depending on which SERCOS motion controller you have, you will also need there:  
QUANTUM:



PREMIUM:

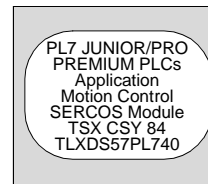
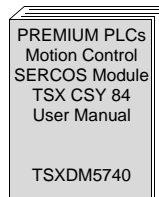

If you have a BPH motor, you will also need this:

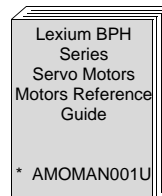

\* included in AM0 CSW 001V\*00 (CDROM)

---

## Hazards, Warnings and Guidelines

---

### Hazards and Warnings

Read the following precautions very carefully to ensure the safety of personnel at your site. Failure to comply will result in death, serious injury or equipment damage.



#### **DANGER!**

#### **ELECTRIC SHOCK HAZARDS**

- During operation, keep all covers and cabinet doors closed.
- Do not open the drives; depending on degree of enclosure protection, the drives may have exposed components.
- Control and power connections on the drive may be energized even if the motor is not rotating.
- Never attempt to disconnect the electrical connections to the drive with power applied. Failure to comply may result in arcing at the contacts.
- Wait at least five minutes after disconnecting the drive from the mains supply voltage before touching energized sections of the equipment (for example, contacts) or disconnecting electrical connections. Capacitors can still have dangerous voltages present up to five minutes after switching off the supply voltages. To ensure safety, measure the voltage in the DC Link circuit and wait until it has fallen below 40V before proceeding.
- Check to ensure all energized connecting elements are protected from accidental contact. Lethal voltages up to 900V can be present. Never disconnect any electrical connections to the drive with power applied; capacitors can retain residual and dangerous voltage levels for up to five minutes after switching off the supply power.

**Failure to follow any one of these instructions will result in death, serious injury or equipment damage.**

---

*Continued on next page*

---

## Hazards, Warnings and Guidelines, continued

---



### **WARNING!**

#### **THERMAL HAZARD**

During operation, the front panel of the drive, which is used as a heat sink, can become hot and may reach temperatures above 80°C. Check (measure) the heat sink temperature and wait until it has cooled below 40°C before touching it.

**Failure to observe this precaution can result in severe injury.**

---



### **WARNING!**

#### **OVERCURRENT, OVERLOAD AND OVERHEATING PROTECTION**

Separate motor overcurrent, overload and overheating protection is required to be provided in accordance with the Canadian Electrical Code, Part 1 and the National Electrical Code.

**Failure to observe this precaution can result in severe injury.**

---

*Continued on next page*

---

## Hazards, Warnings and Guidelines, continued

---



### CAUTION!

#### SAFETY INTERLOCKS

Schneider recommends the installation of a safety interlock with separate contacts for each motor. Such a system should be hard wired with over-travel limit switches and a suitable emergency stop switch. Any interruption of this circuit or fault indication should:

- Open the motor contacts
- Shunt dynamic braking resistors across each motor, if they are present.

**Failure to observe this precaution can result in equipment damage.**

---



### CAUTION!

#### ELECTROSTATIC COMPONENTS

The drives contain electrostatically sensitive components that may be damaged by improper handling. Appropriately discharge yourself before touching the drive and avoid contact with highly insulating materials (artificial fabrics, plastic film, and so on). Place the drive on a conductive surface.

**Failure to observe this precaution can result in equipment damage.**

---

*Continued on next page*

---

## Hazards, Warnings and Guidelines, continued

---

### **Additional Safety Guidelines**

Read this documentation and adhere to the safety guidelines contained herein before engaging in any activities involving the drives.

- Ensure that all wiring is in accordance with the National Electrical Code (NEC) or its national equivalent (CSA, CENELEC, and so on), as well as in accordance with all prevailing local codes.
- Exercise extreme caution when using instruments such as oscilloscopes, chart recorders, or volt–ohm meters with equipment connected to line power.
- Handle the drives as prescribed herein. Incorrect handling can result in personal injury or equipment damage.
- Adhere to the technical information on connection requirements identified on the nameplate and specified in the documentation.
- The drives may only be operated in a closed switchgear cabinet with appropriate compensation for ambient conditions (as defined in Appendix A).

### **Qualified Personnel**

Only properly qualified personnel having extensive knowledge in electrical and drive technologies should install, commission and/or maintain the Lexium 17S SERCOS drives.

---

---

## Standards and Compliances

---

### **European Directives and Standards**

The Lexium 17S SERCOS drives are incorporated into an electrical plant and into machinery for industrial use.

When the drives are built into machines or a plant, do not operate the drive until the machine or plant fulfills the requirements of these European Standards:

- EC Directive on Machines 89/392/EEC
- EC Directive on EMC (89/336/EEC)
- EN 60204
- EN 292

In connection with the Low Voltage Directive 73/23/EEC, the associated standards of the EN 50178 series in conjunction with EN 60439-1, EN 60146 and EN 60204 are applied to the drives.

The manufacturer of the machine or plant is responsible for meeting the requirements of the EMC regulations.

---

### **EC Directive Compliance**

Compliance with the EC Directive on EMC 89/336/EEC and the Low Voltage Directive 73/23/EEC is mandatory for all drives used within the European Community.

The Lexium 17S SERCOS drives were tested by an authorized testing laboratory and determined to be in compliance with the directives identified above.

---

*Continued on next page*

---

## Standards and Compliances, continued

---

### **SERCOS Standard**

If you want to reference the international SERCOS communications standard, get a copy of:

International Standard IEC 1491, *Electrical Equipment of Industrial Machines – Serial Data Link for Real-Time Communication between Controllers and Drives*.

SERCOS is an industry standard term that refers to a special type of fiber–optic communication protocol, as defined by the SERCOS Interface, Inc., promotion society. (SERCOS® interface is a trademark of SERCOS Interface, Inc., promotion society.)

---

### **UL and cUL Compliance**

UL Listed (cUL Certified) drives (Underwriters Laboratories Inc.) comply with the relevant American and Canadian standards (in this case, UL 840 and UL 508C).

This standard describes the minimum requirements for electrically operated power conversion equipment (such as frequency converters and drives) and is intended to eliminate the risk of injury to personnel from electric shock or damage to equipment from fire. Conformance with the United States and Canadian standard is determined by an independent UL (cUL) fire inspector through the type testing and regular checkups.

#### **UL 508C**

UL 508C describes the minimum requirements for electrically operated power conversion equipment (such as frequency converters and drives) and is intended to eliminate the risk of fire caused by that equipment.

#### **UL 840**

UL 840 describes air and insulation creepage spacings for electrical equipment and printed circuit boards.

---

---

## Conventions

---

### Acronyms and Abbreviations

The acronyms and abbreviations used in this manual are identified and defined in the table below.

<b>Acronym or Abbreviation</b>	<b>Description</b>
CE	European Community (EC)
CLK	Clock signal
COM	Serial communication interface for a PC-AT
cUL	Underwriters Laboratory (Canada)
DIN	German Institute for Norming
Disk	Magnetic storage (diskette, hard disk)
EEPROM	Electrically erasable programmable read only memory
EMC	Electromagnetic compatibility
EMI	Electromagnetic Interference
EN	European norm
ESD	Electrostatic discharge
IEC	International Electrotechnical Commission
IGBT	Insulated Gate Bipolar Transistor
ISO	International Standardization Organization
LED	Light Emitting Diode
MB	Megabyte
MS-DOS	Microsoft Disk Operating System for PC-AT
PC-AT	Personal computer in AT configuration
PELV	Protected extra low voltage
PWM	Pulse-width modulation
RAM	Random Access Memory (volatile)
Regen	Regen resistor
RBext	External Regen resistor
RBint	Internal Regen resistor
RFI	Radio Frequency Interference

---

*Continued on next page*



---

## Conventions, continued

### Acronyms and Abbreviations, continued

<b>Acronym or Abbreviation</b>	<b>Description</b>
PLC	Programmable Logic Controller
SERCOS	Serial Realtime Communication System
SRAM	Static RAM
SSI	Synchronous Serial Interface
UL	Underwriters Laboratory
Vac	Voltage, Alternating Current
Vdc	Voltage, Direct Current

---

---

# Product Overview

# 2

---

## At a Glance

### Introduction

This chapter contains a product overview of the Lexium 17S series SERCOS drives and includes:

- Available drive models and related system components
- Feedback and performance information
- Power and signal electronics
- Software and axis configuration

---

### What's in this Chapter

This chapter contains the following topics:

Topic	Page
The 17S series SERCOS drive family	16
Modicon Multi-Axis Motion SERCOS Network Configuration	22
Overview of usability features	25
Overview of 17S internal electronics	27
Overview of system software	31

---

## The 17S Series SERCOS Drive Family

---

### **Introducing the 17S SERCOS Drive Family**

Each member of the Lexium 17S series SERCOS drive family is comprised of a three-phase brushless servo amplifier, power supply, high-performance digital controller and SERCOS fiber optic interface all housed in a single enclosure.

---

### **Drives Available**

The 17S drives are available in five models which are correlated to different output current levels as identified in the following table.

<b>Output Current (Peak)</b>	<b>17S Drive</b>
4.2 A	MHDS1004N00
8.4 A	MHDS1008N00
16.8 A	MHDS1017N00
28 A	MHDS1028N00
56 A	MHDS1056N00

---

### **Implementing the Drives**

The Lexium 17S SERCOS drives are intended for incorporation into electrical equipment or machinery and can only be commissioned as integral components of those types of devices.

---

### **Applicable Servo Motor Types**

The Lexium 17S SERCOS drives are intended to drive BPH series brushless servo motors.

---

*Continued on next page*

---

## The 17S Series SERCOS Drive Family, continued

---

### Electrical Considerations

The Lexium 17S family of servo amplifiers is to be used on earthed three-phase industrial mains supply networks (TN-system, TT-system with earthed neutral point, not more than 5000 rms symmetrical amperes).

The Lexium drives are incompatible with the IT system because interference suppression filters are internal and connected to earth. If the user wants to connect Lexium drives to an IT system, he may:

- use an insulation star transformer in order to re-create a local TT or TN system. This way allows the rest of the wiring to stay an IT system (only warning in case of the first fault.)
- use a special Residual Current Circuit Breaker (RCCB) that is able to work with dc and high peak currents. This device detects unbalance of phases with regard to earth.

Warning: When the first fault occurs, the RCCB has to switch off quickly power of the drives. Set of the residual current value must be carefully done and must be started with the lowest available value (for example: 30mA.)

Following equipment of Merlin Gerin can be used:

- Vigirex, model RH328AF (Reference: 50055)
- One of these magnetic cores:
  - model TA, 30mm in internal diameter (Reference: 50437)
  - model PA, 50mm in internal diameter (Reference: 50438)
  - model IA, 80mm in internal diameter (Reference: 50439)

If the servo amplifiers are used in residential areas, or in business or commercial premises, then additional filter measures must be implemented by the user.

The Lexium 17S family of servo amplifiers is **only** intended to drive specific brushless synchronous servomotors from the Lexium BPH series, with closed-loop control of torque, speed and/or position. **The dielectric withstand voltage of the motors must be at least as high as the DC-link voltage of the servo amplifier.**

Use only copper wire. Wire size may be determined from EN 60204 (or table 310-16 of the NEC 60°C or 75°C column for AWG size).

We only guarantee the conformance of the servo amplifiers with the standards for industrial areas, if the components (motors, cables, amplifiers etc) are delivered by Schneider Automation.

---

*Continued on next page*

---

## The 17S Series SERCOS Drive Family, continued

---

### 17S Drive Family Portrait

The following photograph shows a representative member of the 17S drive family. The complete family consists of five models partitioned into two physical sizes. Models MHDS1004N00, MHDS1008N00, MHDS1017N00 and MHDS1028N00 have dimensionally identical physical housings while Model MHDS1056N00 has a wider housing. (See Chapter 3 for detailed dimensional information.)

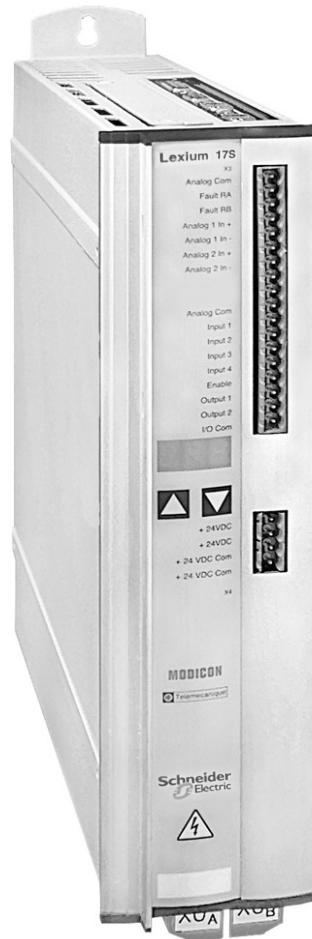

---

*Continued on next page*

---

## The 17S Series SERCOS Drive Family, continued

---

### 17S Drives Front View

The following photograph shows a typical 17S front view with legends and labels.

LED indicator display.  
See Chapter 5.

Keypad. See Chapter 5

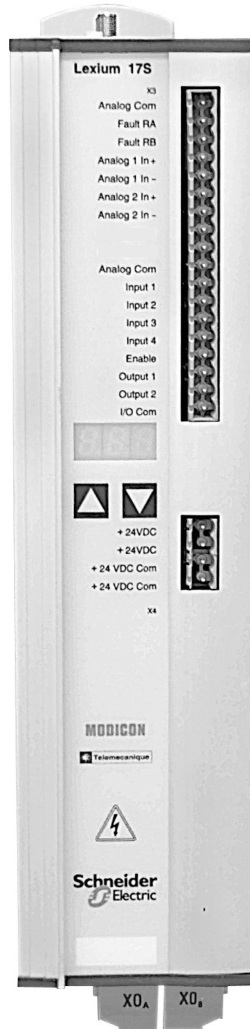

Analog and digital I/O  
connector. See Chapter 4  
for wiring information.

Bias power input  
connector. See Chapter 4  
for wiring information.

---

*Continued on next page*

---

## The 17S Series SERCOS Drive Family, continued

---

### Equipment Supplied

Each 17S SERCOS drive includes the following hardware.

- Mating connectors X3, X4, X0<sub>A</sub>, X0<sub>B</sub>, X7 and X8
- Read me first



**Note:** The mating Sub-D connectors and servo motor connector X9 are supplied with the appropriate cable.

---

### Equipment Available

The following items are optionally available to you from Schneider for use with the 17S SERCOS drives:

- Lexium BPH series brushless servo motors
- Servo motor power and feedback cables



**Note:** Power and feedback cables are available in lengths from 5...75 m and are supplied by Schneider with the connector for the servo motor attached to the cable and with the connector for the drive unassembled and unattached to the cable. The 10 m length cable is supplied (from stock) by Schneider with connectors attached to each end of the cable.

- Optional servo motor choke (for motor power cable lengths exceeding 25m)
  - Optional external Regen resistor
  - Serial communications cable (between drive and PC)
  - SERCOS fiber optic cables in lengths of 0.3...38 m
- 

*Continued on next page*



---

## The 17S Series SERCOS Drive Family, continued

---

### 17S System Configuration Diagram

The following illustration shows a typical 17S system configuration.

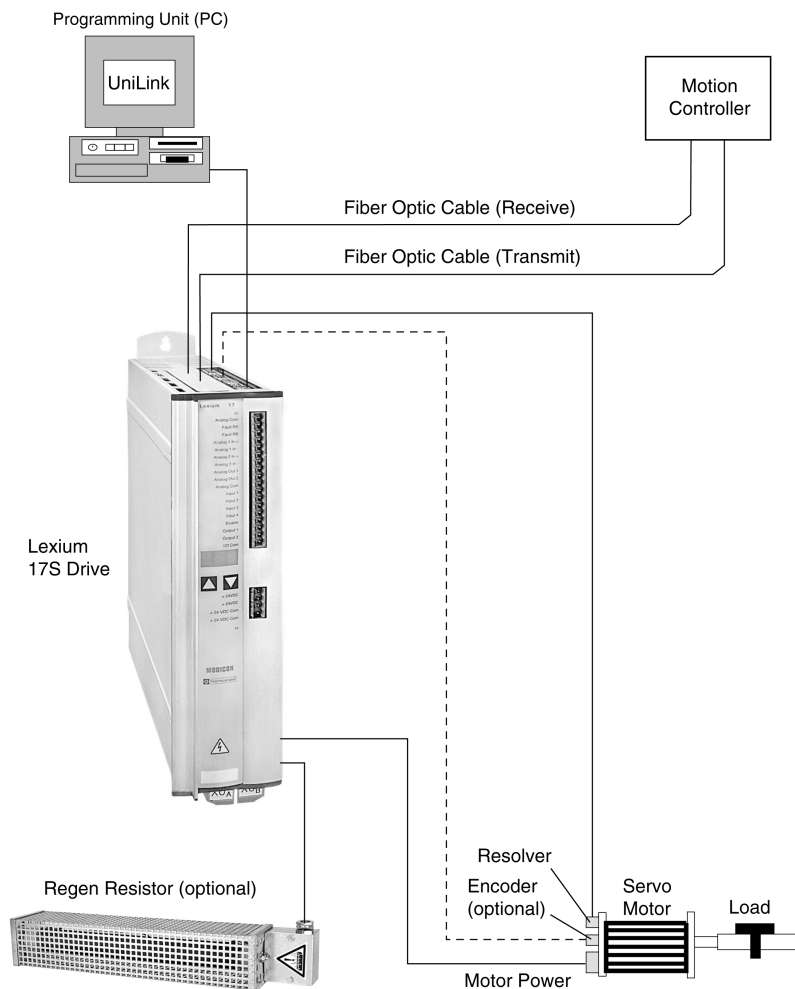

**Note:** Connections are simplified to show functionality only. Refer to Wiring and I/O for specific connection information.

---

---

## Modicon Multi-Axis Motion SERCOS Network Configuration

---

### Overview

The 17S drive is typically configured in a SERCOS network containing many axes. A Schneider multi-axis motion controller configured with a SERCOS processor board transmits motion instructions to all the 17S drives that are properly configured in the fiber-optic loop.

---

### Which Motion Controllers run a SERCOS Network

The controller that runs a network of many SERCOS axes is a Modicon Quantum Automation Series SERCOS multi-axis motion controller (part number 141MMS42501) or TSX Premium CSY motion controller. Each controller supports one independent SERCOS network ring. Each ring can contain up to 8 axes (8 drives and their motors). The 17S may also be configured with a compatible non-Modicon SERCOS controller. Schneider also offers a 32-axis motion controller (part number 141MMS53502).

---

### SERCOS Fiber-Optic Transmit and Receive Connectors

Each 17S drive has two SERCOS-compliant SMA type fiber-optic connectors:

- TX (transmit)
- RX (receive)

Through a SERCOS-compliant, fiber-optic cable, the RX connector receives the controller's command instructions (as well as actual motion information from the previous axes) from the previous drive in the ring. Likewise, the TX connector transmits the controller's command instructions (along with actual motion information from the axes) to the next drive in the ring. The SERCOS multi-axis motion controller also has a fiber-optic transmitter (TX) connector and a fiber-optic receiver (RX) connector. The transmitter sends command instructions (*commanded motion*) to all the 17S axes in the network ring. The receiver accepts real feedback (*actual motion information*) from all the axes in the ring. Transmission flows in one direction, with typical cycle times of 2ms to 4ms, depending on the number of drives, volume of data, and data rate.

---

*Continued on next page*

---

## Modicon Multi-Axis Motion SERCOS Network Configuration, continued

---

### Example of a Typical SERCOS Network Ring Configuration

The following figure shows a typical configuration of 17S SERCOS axes with arbitrary node addresses receiving and transmitting instructions from a multi-axis motion controller.

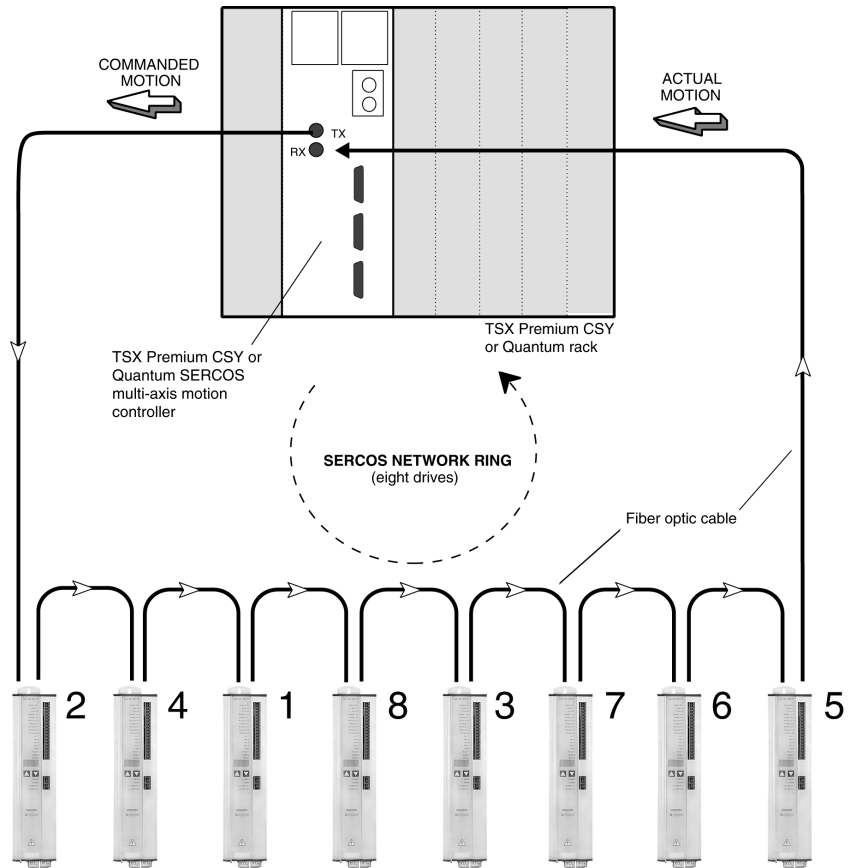

*Continued on next page*

---

## Modicon Multi-Axis Motion SERCOS Network Configuration, continued

---

### Example of a Typical SERCOS Network Ring Configuration, continued

As shown in the figure, the ring has eight axes. These axes need not be configured sequentially. Any axis in the ring can be identified as axis 1, axis 2, axis 3, and so on. However, each address within a ring must be unique.

---

### Benefits of Fiber-Optic Communication

The SERCOS multi-axis motion controller coordinates the motion activities of the various SERCOS axes on the network ring. Fiber optic communication allows efficient synchronization of multiple axes through flexible SERCOS networking rather than through a constraining backplane bus configuration. SERCOS networking allows you to place each drive close to its motor. This reduces and eliminates cumbersome wiring from the motor to the controller. The fiber-optic SERCOS protocol provides complete electrical isolation between drive axes as well as between each drive axis and the motion controller. This eliminates wiring difficulties, such as ground loops, which are present in hard-wired systems.

---

### Two Types of Fiber-Optic Communication

The SERCOS protocol allows two types of communication simultaneously throughout the network ring:

- Constant real-time data updates
- Slower intermittent messaging

This flexibility allows the communication to serve many different types of motion applications.



**Note:** For more information on fiber optic connections and signal wiring, see Chapter 4 and Appendix C.

---

---

## Overview of Usability Features

---

### **Digital Control**

The 17S drive provides complete digital control of a brushless servo system. This includes:

- A digital field-oriented current controller operating at an update rate of 62.5  $\mu$ s
- A fully programmable digital PI-type speed controller operating at an update rate of 250  $\mu$ s
- Full digital evaluation of motor position feedback (primary feedback) from either a standard two-poles resolver or a high precision Sin-Cos type encoder (hiperface).

---

*Continued on next page*

---

## Overview of Usability Features, continued

---

### **Usability Enhancements**

The following features are incorporated into the 17S drive to facilitate the set-up and operation of the servo system:

- Two analog +/-10 V inputs can be programmed for a multitude of functions depending upon the application. Both inputs incorporate automatic offset compensation, dead-band limitation and slew-rate limitation.
  - Four fully programmable 24 V discrete inputs; two of which are typically defined as hardware limit switches.
  - Two fully programmable 24 V outputs and a separate 24 V brake output capable of driving a maximum of 2 Amps.
  - An integrated and fully isolated RS-232 connection for communication with a PC; used to set configuration parameters and tune the system with the Unilink configuration software.
  - A separate 24V bias supply input which may be connected through a UPS to preserve system data in the event of an interruption in the AC mains supply.
-

# Overview of 17S Internal Electronics

## 17S Internal Electronics Block Diagram

The following block diagram illustrates the 17S internal electronics and depicts internal interfaces for power, signal I/O, and communication.

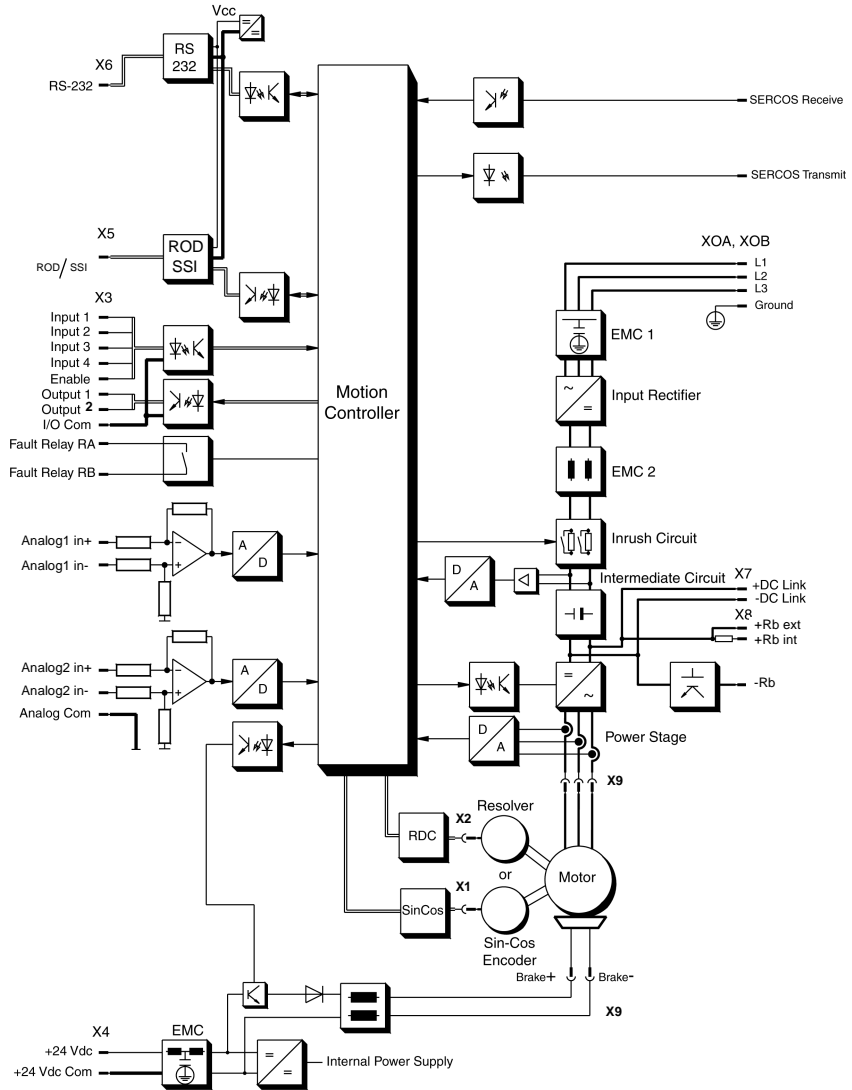

*Continued on next page*

---

## Overview of 17S Internal Electronics, continued

---

### **General Characteristics**

The Lexium 17S SERCOS drives are available in five peak output current ratings (4.2, 8.4, 16.8, 28 and 56 A) that are partitioned into two groups based on the width of the package; the 70 mm drives are rated to handle currents up to 28 A and the 120 mm wide drive is rated to handle currents up to 56 A. All Lexium drives operate with an input voltage which may range from 208 V -10% 60 Hz, 230 V -10% 50 Hz through 480 V +10% 50-60 Hz.

Each drive provides:

- Direct shield connection points
  - Two analog setpoint inputs
  - Integrated and electrically isolated RS-232 communications
- 

### **Primary Power**

A single phase input supply may be used for commissioning and set-up and for continuous operation with various smaller drive/motor combinations. See the Lexium 17/ BPH motor torque speed curves for details. Fusing (e.g. fuse cut-out) is provided by the user.

---

### **Bias Power**

The 17S drive requires 24 Vdc bias power from an external, electrically isolated supply.

---

### **EMI Suppression**

EMI suppression for the 17S drives is integrally provided by filters on both the primary power (EN550011, Class A, Group 1) input as well as on the 24 Vdc bias supply (Class A) input.

---

*Continued on next page*



---

## Overview of 17S Internal Electronics, continued

---

### Internal Power Section

The Internal power section of the 17S drive includes the following:

- Power input: A rectifier bridge directly connected to the three-phase earthed supply system, integral power input filter and inrush current limiting circuit.
  - Motor power output: PWM current-controlled voltage source IGBT-inverter with isolated current measurement
  - Regen circuit: Dynamic distribution of Regen power between several drives on the same DC Link circuit. An internal Regen resistor is standard; optional external Regen resistors are available as required by your application.
  - DC Link voltage: 300...700 Vdc, nominal (900 Vdc, intermittent) and can be operated in parallel.
- 

### DC Link Capacitor Reconditioning

If the servo drive has been stored for longer than one year, then the DC Link capacitors will have to be reconditioned as follows:

Step	Action
1	Ensure that all electrical connections to the drive are disconnected.
2	Provide 230 Vac, single-phase power to connector XO <sub>A</sub> (terminals L1/L2) on the servo drive for about 30 minutes to recondition the capacitors.

---

### Integrated Safe Electrical Separation

The 17S drive ensures safe electrical separation (in accordance with EN 50178) between the power input/motor connections and the signal electronics through the use of appropriate insulation-creepage distances and electrical isolation. The drive also provides soft-start characteristics, overvoltage and overtemperature detection, short-circuit protection and input phase-failure monitoring. When using BPH series servo motors in conjunction with Schneider's pre-assembled cables, the drive also monitors the servo motor for overtemperature.

---

### Keypad

The operation of the keypad on the front panel of the 17S drive is described in System Operation. These two keys can be used (as an alternative to using the PC) to enter the SERCOS address for the drive

---

---

---

**LED Display and  
Discrete  
Indicators**

A three-character LED display on the front of the 17S drive indicates drive status after the 24 Vdc bias supply is turned on. If applicable during operation, error and/or warning codes are displayed. In addition, three individual LED indicators (one red and two green) on the SERCOS communication card (at the top of the drive) are used to indicate the status of that communications.

---

*Continued on next page*

---

## Overview of System Software

---

### Setup

Configuration software is used for setting up and storing the operating parameters for the Lexium 17S series drives. The drive is commissioned with the assistance of the UniLink software and, during this process, the drive can be controlled directly through this software.

---

### Setting Parameters

You must adapt the SERCOS drives to the requirements of your installation. This is usually accomplished by connecting a PC (programming unit) to the drive's RS-232 serial interface then running the Schneider-supplied UniLink configuration software.

The UniLink software and the associated documentation are provided on a CD-ROM. Use the UniLink software to alter parameters; you can instantly observe the effect on the drive because there is a continuous (online) connection to the drive. In addition, actual values are simultaneously received from the drive and displayed on the PC monitor.

---

### Default Settings

Motor-specific default settings for all the reasonable combinations of drive and servo motor are incorporated into the drive's firmware. In most applications, you will be able to use these default values to get your drive running without any problems. (Refer to the UniLink online help for additional information on default values.)

---

*Continued on next page*

---

## Overview of System Software, continued

---

### UniLink Commissioning Software

The minimum PC system requirements needed for the UniLink commissioning software are specified in the following table:

Item	Minimum Requirement
Operating System	Windows 95 Windows 98
Hardware:	
Processor	486 or higher
Graphics adapter	VGA
RAM	8 Mbytes
Hard drive space	5 Mbytes available
Communications	One RS-232 serial port

---

---

# Mounting and Physical Dimensions

# 3

---

## At a Glance

### What's in this Chapter

This chapter provides information on the mounting requirements for, and physical dimensions of, the Lexium 17S series SERCOS drives and includes the following topics:

Topic	Page
Installation safety precautions	34
Installation considerations	36
Drive mounting and physical dimensions	37
Optional external Regen resistor mounting and dimensions	39
Optional choke mounting and dimensions	40

---

---

## Installation Safety Precautions

---



### **CAUTION!**

#### **MECHANICAL STRESS**

Protect the drive from physical impact during transport and handling. In particular, do not deform any exterior surfaces; doing so may damage internal components or alter critical insulation distances.

**Failure to observe this precaution can result in injury or equipment damage.**

---



### **CAUTION!**

#### **ELECTRICAL STRESS**

At the installation site, ensure the maximum permissible rated voltage at the Mains and bias input connectors on the drive are not exceeded. (See EN 60204-1, Section 4.3.1.) Excessive voltages on these terminals can result in destruction of the Regen circuit and/or the drive's electronics.

**Failure to observe this precaution can result in injury or equipment damage.**

---



### **CAUTION!**

#### **ELECTRICAL CONNECTIONS**

Never disconnect the electrical connections to the SERCOS drive while power is applied.

**Failure to observe this precaution can result in injury or equipment damage.**

---

*Continued on next page*

---

## Installation Safety Precautions, continued

---



### **CAUTION!**

#### **CONTAMINATION AND THERMAL HAZARD**

Ensure the 17S drive is mounted within an appropriately vented and closed switchgear cabinet that is free of conductive and corrosive contaminants. Ensure the ventilation clearances above and below the drive conform to requirements. (Refer to Chapter 3 for additional information.)

**Failure to observe this precaution can result in injury or equipment damage.**

---



### **DANGER!**

#### **ELECTRIC SHOCK HAZARD**

Residual voltages on the DC link capacitors can remain at dangerous levels for up to five minutes after switching off the mains supply voltage. Therefore, measure the voltage on the DC Link (+DC/-DC) and wait until the voltage has fallen below 40 V.

Control and power connections can still be energized, even when the motor is not rotating.

**Failure to observe these instructions will result in death or serious injury.**

---

---

## Installation Considerations

---

### **Power Supply Overcurrent Protection**

You are responsible for providing overcurrent protection (via circuit breakers and/or fuses) for the Vac mains supply and the 24 Vdc bias supply that are connected to the drive.

---

### **Earth Connections**

Ensure the drive and associated servo motor are properly connected to earth.

---

### **Cable Separation**

Route power and control (signal) cables separately. Schneider recommends a separation of at least 20 cm. This degree of separation improves the performance of the system. If a servo motor power cable includes wires for brake control, those wires have a separate shield which must be connected to earth at both ends of the cable.

---

### **Air Flow**

Ensure that there is an adequate flow of cool, filtered air into the bottom of the switchgear cabinet containing the drive.

---



---

## Drive Mounting and Physical Dimensions

---

### 17S Height, Width and Depth Dimensions

The following diagram shows height, width and depth dimensions for the 17S drive.

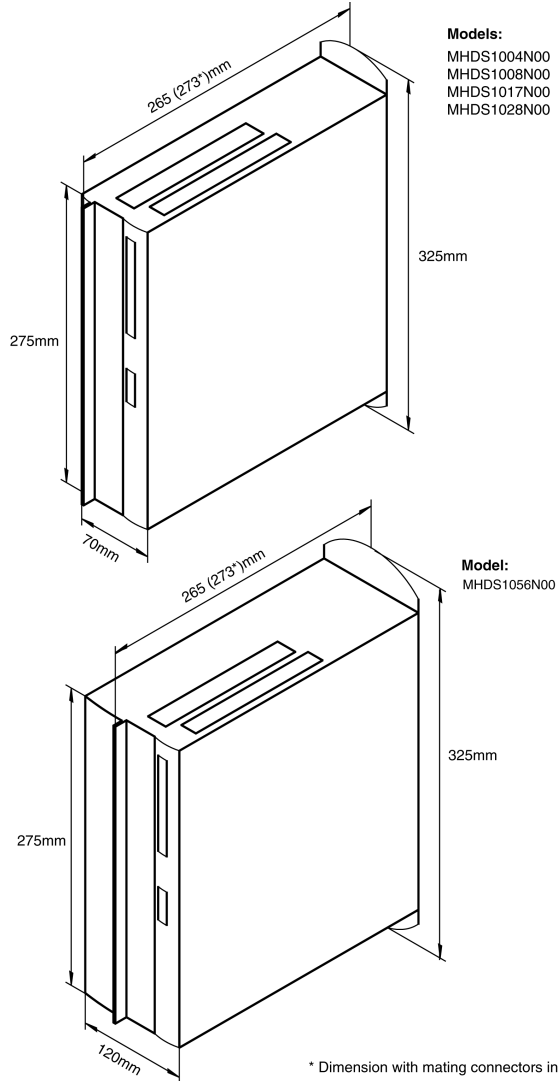

---

*Continued on next page*

## Drive Mounting and Physical Dimensions, continued

### 17S Drive and Mounting Area Dimensions

The following diagram shows depth dimensions and mounting area requirements for the 17S drive.

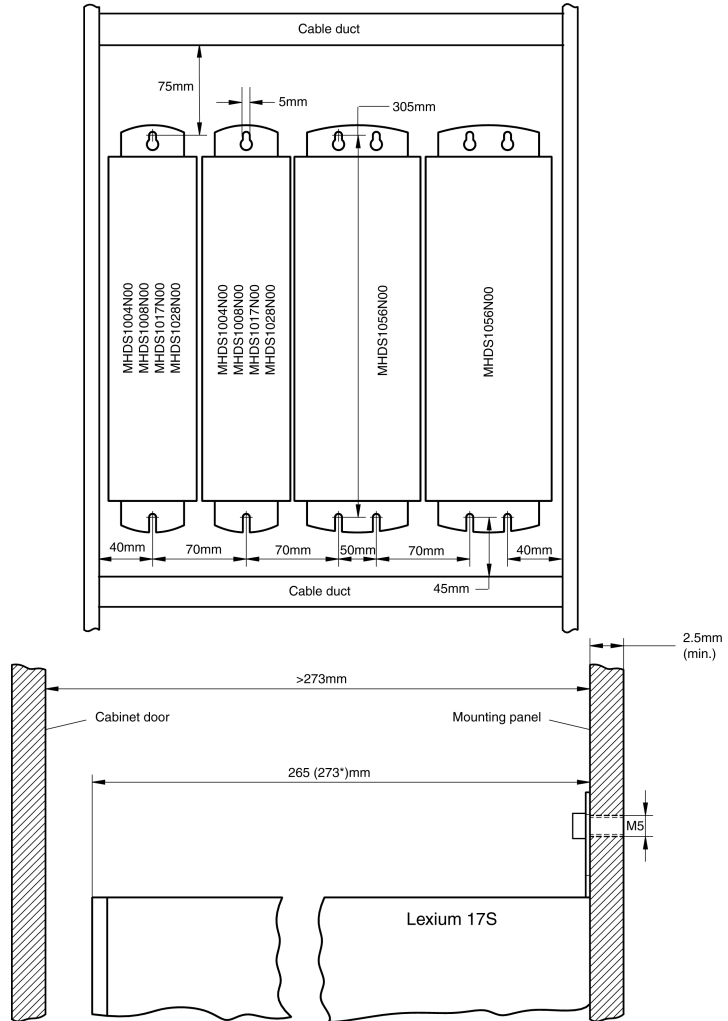

\* Dimension with mating connectors installed.

## Optional External Regen Resistor Mounting and Physical Dimensions

### Optional External Regen Resistor Assembly Dimensions

The following diagram shows the dimensions for all three optional external Regen resistor assemblies.

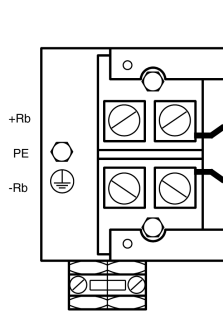
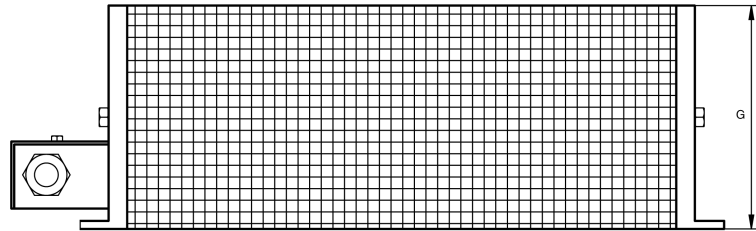
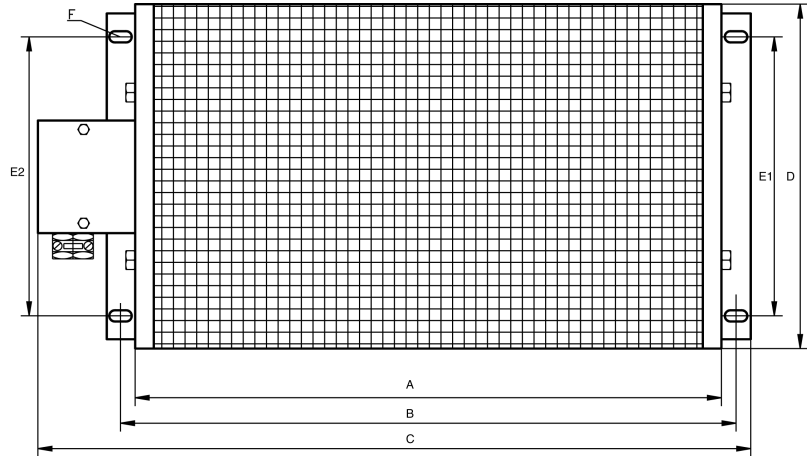

Regen Resistor Assembly Part Number	R $\Omega$	A mm	B mm	C mm	D mm	E1 mm	E2 mm	F mm	G mm	Weight Kg
AMORFE001V025	33	330	390	412	66	44	35	4.5 x 9	77	1.2
AMORFE001V050	33	400	426	486	92	64	64	6.5 x 12	120	2.3
AMORFE001V150	33	500	526	586	185	150	150	6.5 x 12	120	5.2

---

## Optional Motor Choke Mounting and Dimensions

---

### Optional Motor Choke Assembly Dimensions

The following diagram shows the dimensions for the motor choke assembly

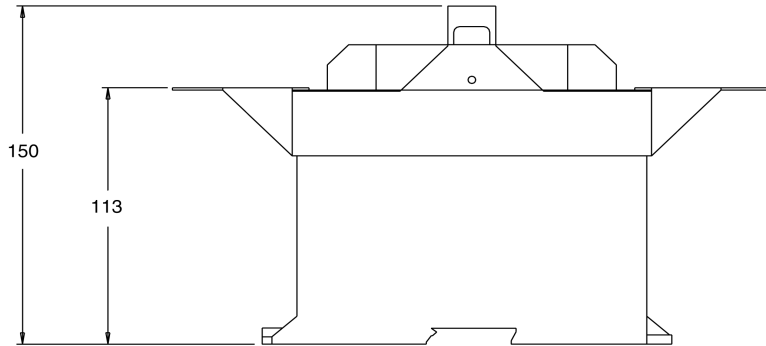
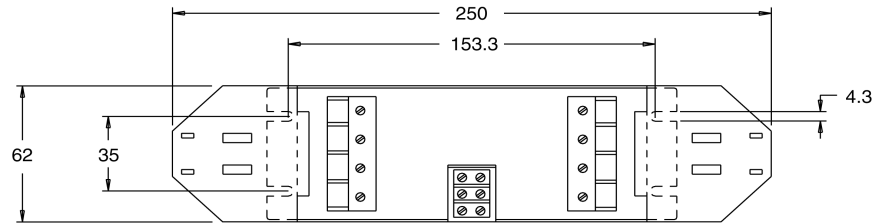

**Note:** All dimensions are in millimeters (mm).

Ref.	I <sub>rms</sub> max.	F max.	L
AM0FIL001V056	3 x 20 A	8.3 kHz	1.2 mH

---

# Wiring and I/O

# 4

---

## At a Glance

### Introduction

This chapter describes and illustrates all power wiring connections, all signal wiring connections, and I/O wiring connections on the 17S drive. Power and signal wiring connections are:

- **AC mains power** through a four-position, plug-in, terminal block connector
- **Bias power** through four-position, plug-in, terminal block connector
- **Serial power connections** among multiple drives
- **Servo motor power** through a six-position, plug-in, terminal block connector
- **Optional Regen power resistor** through a four-position, plug-in, terminal block connector
- **Resolver feedback input** through a nine-pin, plug-in, Sub-D connector
- **Encoder feedback input** through a 15-pin, plug-in, Sub-D connector
- **Auxiliary encoder interface** through a nine-pin, plug-in, Sub-D connector
- **Fiber optic Interface** through two SMA connectors
- **Analog in and digital I/O** through an 18-position, plug-in terminal block connector
- **Serial communications interface** through a nine-pin, plug-in, Sub-D connector

---

*Continued on next page*

---

## At a Glance, continued

---

### What's in this Chapter

This chapter contains the following topics.

<b>Topic</b>	<b>Page</b>
Wiring and I/O initial considerations	43
Wiring overview	44
Cable shield connections	47
Power wiring	49
Signal wiring	57
Analog input connections	63
Fault Relay and Digital I/O connections	64
Serial communications connections	66

---

---

## Wiring and I/O Initial Considerations

---

### Initial Considerations

Some descriptions and illustrations contained in this chapter are provided as examples. Actual implementation depends on the application of the equipment; thus, appropriate variations are allowed provided they neither violate any safety precautions nor jeopardize the integrity of the equipment.

---



### **DANGER!**

### **ELECTRIC SHOCK HAZARD**

Before you wire and connect cables, ensure the mains power supply, the 24 Vdc bias power supply and the power supplies to any other connected equipment, are OFF. Ensure any cabinet to be accessed is first electrically disconnected, secured with a lock-out and tagged with warning signs.

**Failure to observe these safety instructions will result in death or serious injury.**

---

### Grounding

Ensure the drive mounting plate, SERCOS motor housing and Analog Com for the controls are connected to common panel earth ground point.

---

*Continued on next page*

---

## Wiring Overview

---

### Overview of 17S Wiring Connections

The following diagram shows the wiring connections for the 17S drive.



**CAUTION:**

**Do not connect a Modbus serial port to the X6 connector!**

Pin1 carries +8 Vdc which would be shorted out by a Modbus cable.

Instead, use a standard 3-core null-modem cable (not a null-modem link cable) with only pins 2, 3 and 5 wired.

**Failure to observe this precaution can result in equipment damage.**

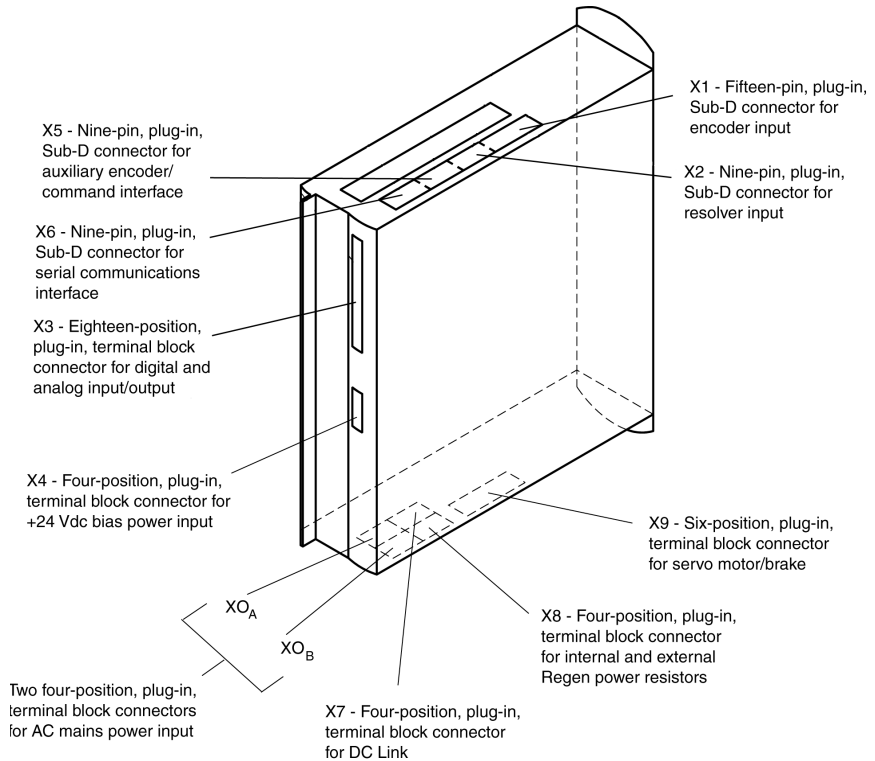

**Note:** The connectors described above appear in many wiring diagrams throughout the remainder of this document and are identified in those diagrams by their alphanumeric designations only (for example, X4); the term *connector* is excluded.

---



## Connection diagram for Lexium 17S

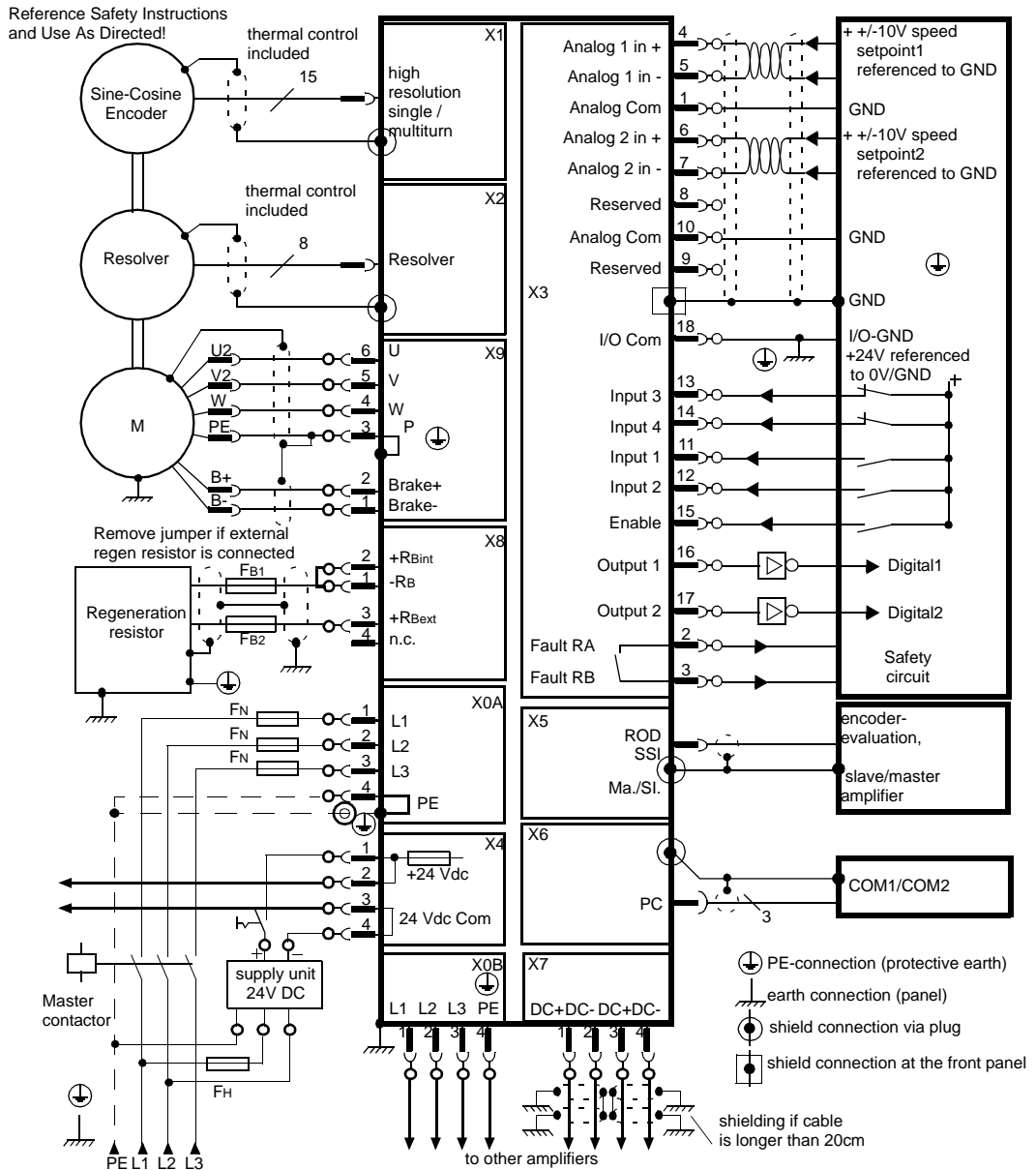

## Pin assignments for LEXIUM 17 S

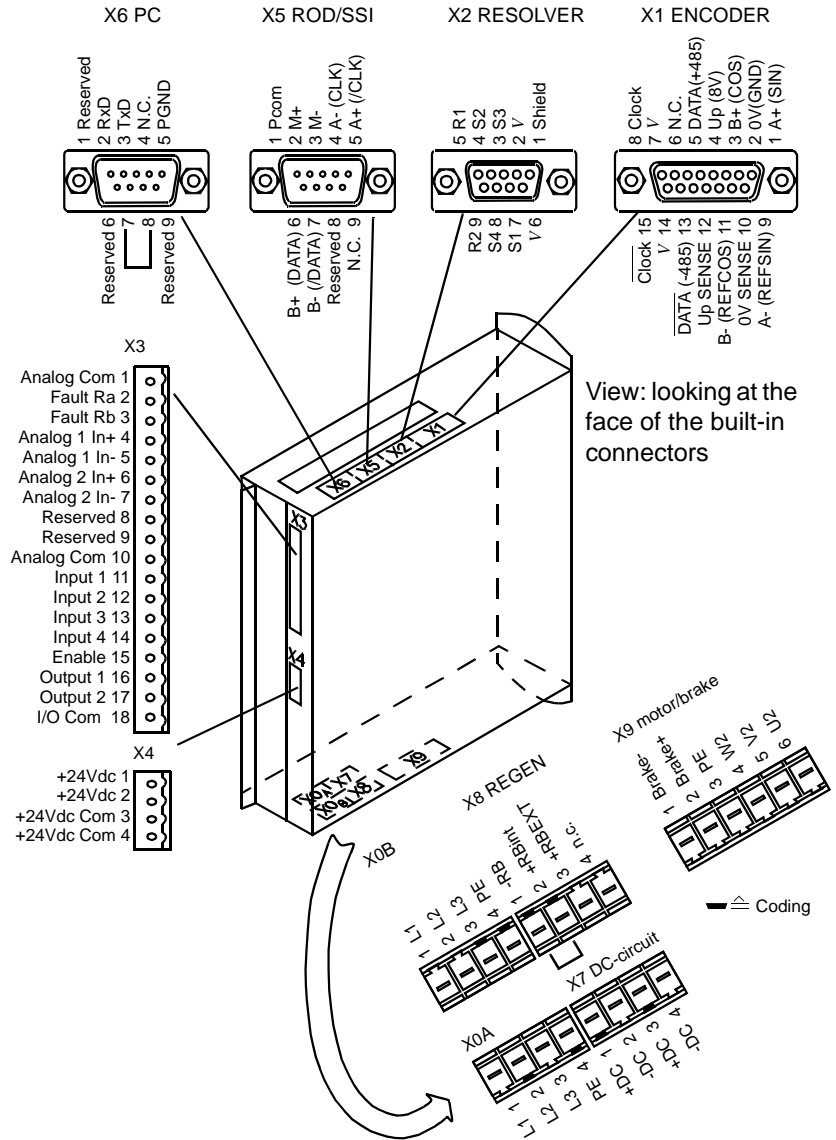

Continued on next page

---

## Cable Shield Connections

---

### Connecting Cable Shields to the Front Panel

The following procedure and associated diagram describe how to connect cable shields to the front panel of the 17S drive:

Step	Action
1	Remove a length of the cable's outer covering and braided shield sufficient to expose the required length of wires.
2	Secure the exposed wires with a cable tie.
3	Remove approximately 30 mm of the cable's outer covering while ensuring the braided shield is not damaged during the process.
4	At the front panel of the drive, insert a cable tie into a slot in the shielding rail.
5	Use the previously inserted cable tie to secure the exposed braided shield of the cable firmly against the shielding rail.

---

*Continued on next page*

---

## Cable Shield Connections, continued

---

### Cable Shield Connection Diagram

The following diagram shows the cable shield connections at the front of the 17S drive.

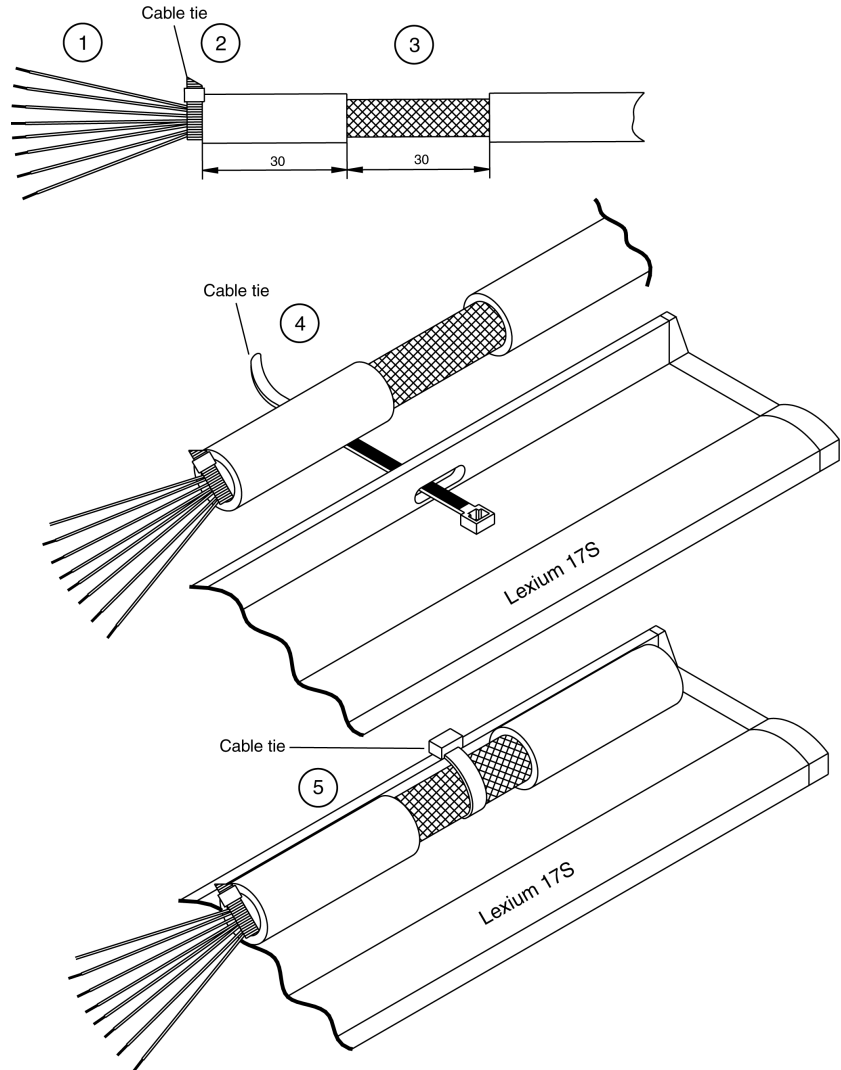

## Power Wiring

### AC Mains Power Supply Connection

The following diagram shows the connections for the AC mains power supply input to the 17S drive.

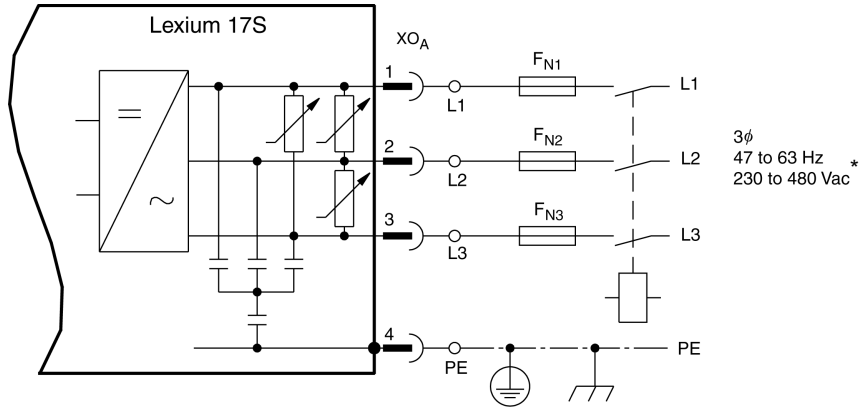

\*3 x 230 V +10% max. with a BPH055 Servo motor

### Bias Supply Connection

The following diagram shows the connections for the bias power supply input to the 17S drive.

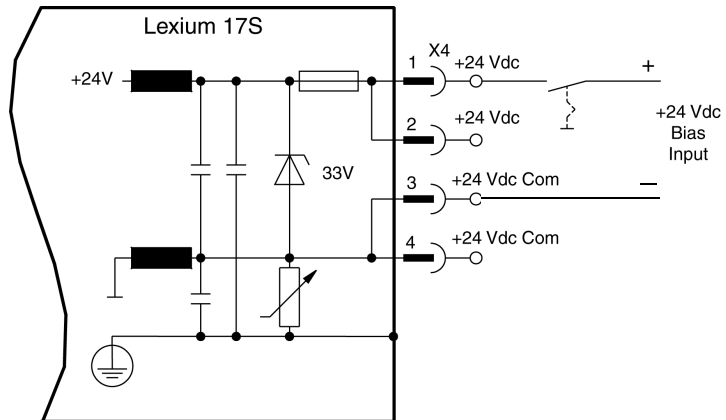

*Continued on next page*

## Power Wiring, continued

### Serial Power Connections

The following diagram shows the serial connections for the AC mains and bias power among multiple 17S drives.

#### AC supply

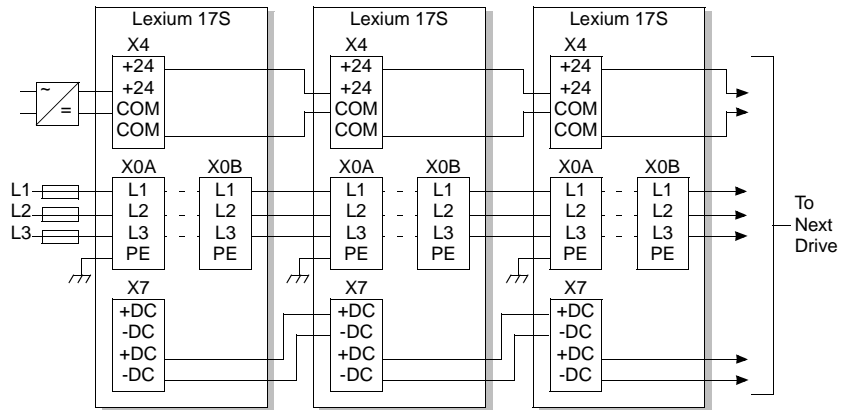

#### DC supply

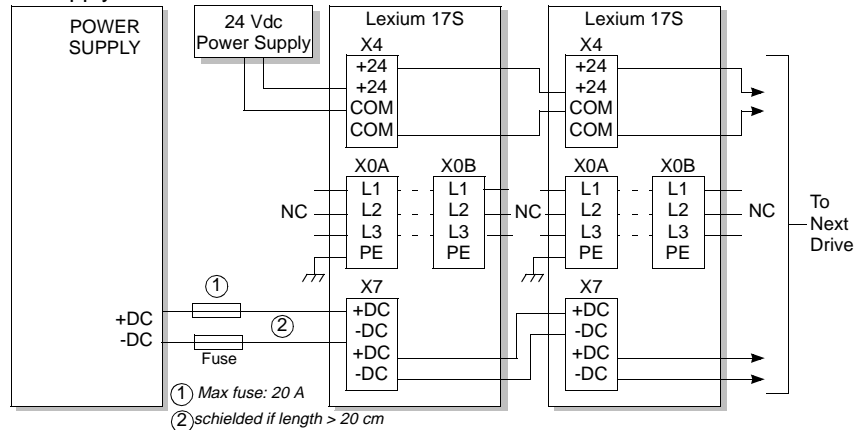

**Notes:** -Inrush current must be limited to 20 A between power supply and drives.  
- Drives have to be configured (see Unilink commands) to suppress faults.

*Continued on next page*

---

## Power Wiring, continued

---

### Optional External Regen Resistor Connection

The following diagram shows the connections between the optional external Regen resistor and the 17S drive. The drive is shipped with a jumper installed on connector X8, terminals  $R_B$  and  $R_{Bint}$ . If you are going to use an optional external Regen resistor, then remove the jumper to disconnect (and thus disable) the internal Regen resistor.

#### Fusing of the two lines to external Regen Resistor is mandatory.

Use high voltage AC/DC and fast fuses.

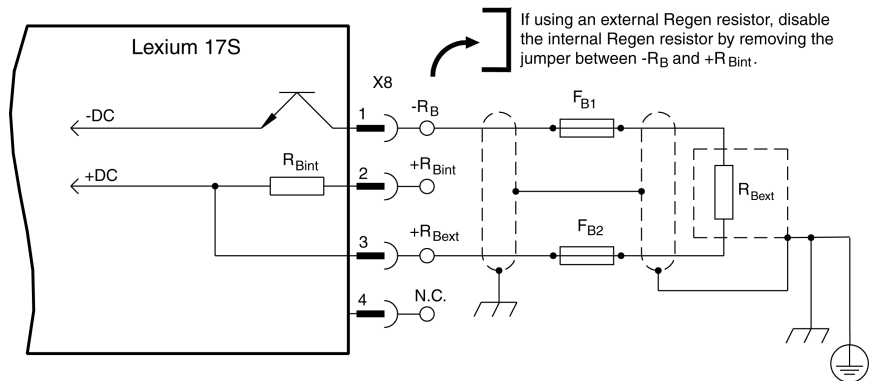

---

### Regen Circuit Functional Description

During braking, energy from the servo motor is returned to the drive and converted into heat in the Regen resistor. Operation of the Regen resistor is controlled by the Regen circuit using thresholds that are adjusted to the main supply voltage that is configured in the UniLink software. The following is an abbreviated functional description of the Regen circuit operation.

- **Individual drive** (not coupled through the DC Link circuit) - The circuit starts to respond at a DC Link voltage of 400V, 720V or 840V (depending on the supply voltage). If the energy fed back from the servo motor is higher than the preset Regen power, then the drive issues a "Regen power exceeded" signal and the Regen circuit will be switched off. Upon the next internal check of the DC Link voltage, an overvoltage will be detected, the fault relay contact will be opened and the drive will be switched off with the error message "Overvoltage".
- **Multiple drives** (coupled through the DC Link circuit) - In this case, the Regen energy is distributed equally among all the drives.

*Continued on next page*

## Power Wiring, continued

### Lexium BPH Servo Motor Connection (excluded BPH055)

The following diagrams show the connections between a servo motor (excluded BPH055) and the 17S drive. When the interface cable length exceeds 25 m, a motor choke must be installed as shown and at a distance of one meter or less from the drive.

Connection between servo motor and drive when interface cable length is 25 m or less.

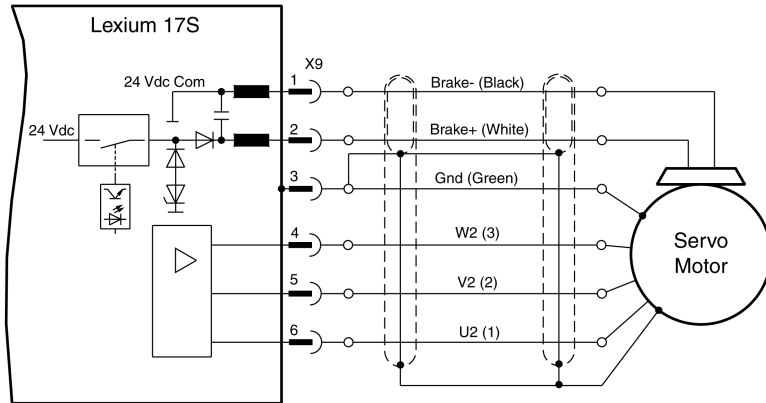

Connection between servo motor and drive when interface cable length exceeds 25 m.

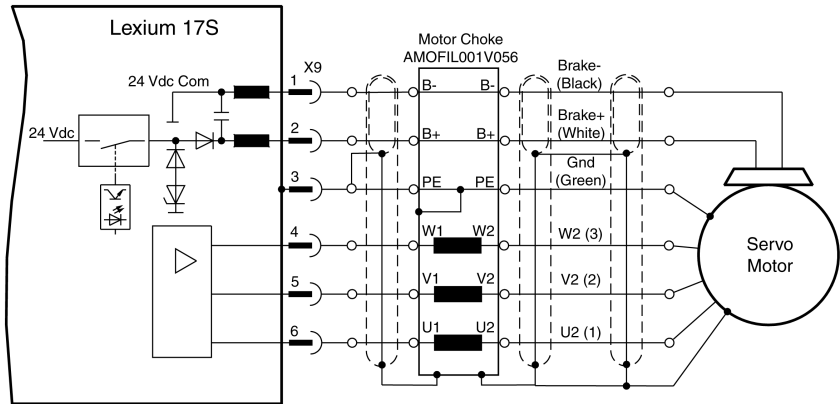

**Note:** The choke must be installed at a distance of one meter or less from the drive

*Continued on next page*



## Power Wiring, continued

### Lexium BPH 055 Servo Motor Connection

The following diagrams show the connections between a BPH055 servo motor and the 17S drive. When the interface cable length exceeds 25 m, a motor choke must be installed as shown and at a distance of one meter or less from the drive.

Connection between servo motor and drive when interface cable length is 25 m or less.

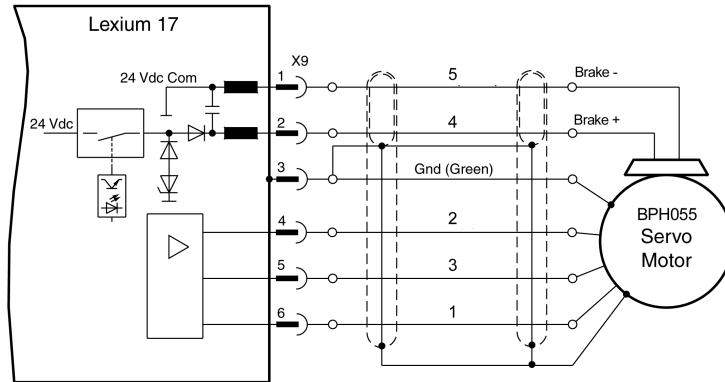

Connection between servo motor and drive when interface cable length exceeds 25 m.

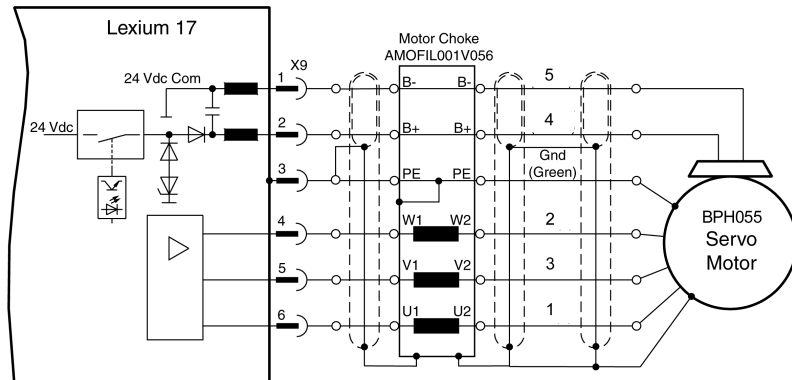

**Note:** The choke must be installed at a distance of one meter or less from the drive



### WARNING!

With a BPH055 Servo motor, power supply of the 17S drive must be limited to 3 x 230 Vac +10%

## Power Wiring, continued

### Servo Motor (with Optional Dynamic Brake Resistors and Contactor) Connection

The following diagram shows the connections between a servo motor and the 17S drive when the optional dynamic brake resistors and associated contactor are incorporated.

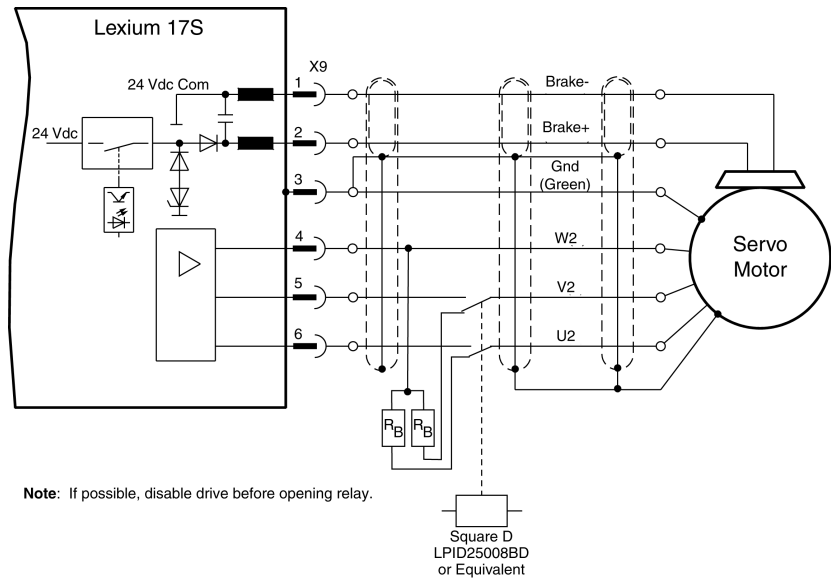

**Note:** If possible, disable drive before opening relay.

**BRAKING RESISTORS** - To determine the values of the braking resistors, use these formulas:

MINIMUM RESISTANCE (R<sub>db</sub>)

$$R_b = \frac{\left( \frac{\text{max speed}}{1000} \right) \times \text{BEMF}}{I_{\text{MAX}} \times 0.8}$$

RESISTOR POWER RATING (P<sub>b</sub>)

$$P_b = \frac{\left( I_{\text{MAX}} \times 0.8 \right)^2 \times R_b}{10}$$

where: **max speed** is the maximum speed of the motor in RPM\*

**BEMF** is the back electromotive force of the motor in V / KPRM\*

**IMAX** is the maximum current of the motor in Amps RMS\*

\* These values are provided in the motor specification sheet.

*Continued on next page*

## Power Wiring, continued

### Servo Motor Holding-Brake Control Functional Description

A 24V holding brake in the servo motor is controlled directly by the 17S drive through software-selectable BRAKE parameter settings. The time and functional relationships between the ENABLE signal, speed setpoint, speed and braking force are shown in the following diagram.

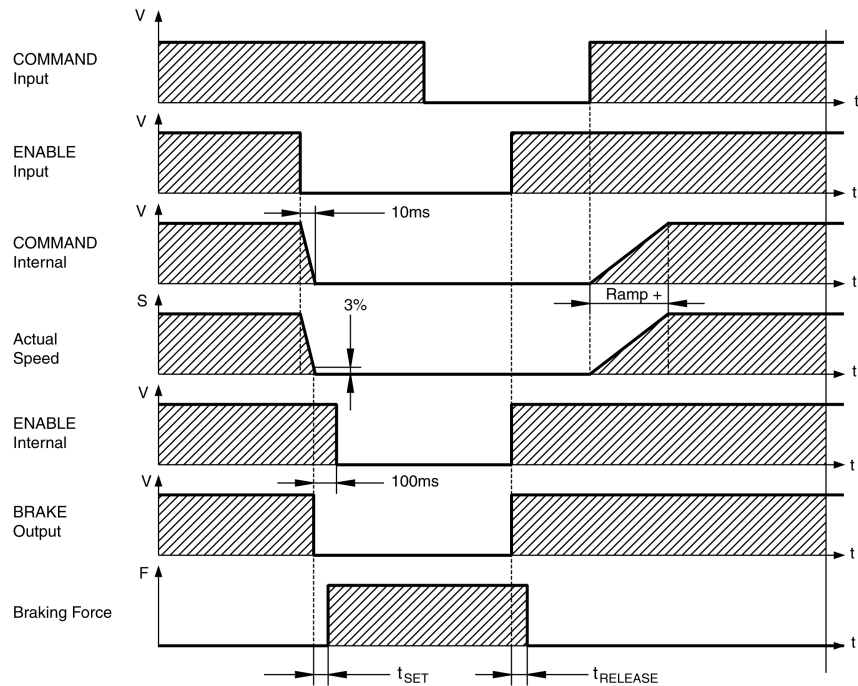

During the fixed ENABLE delay time of 100 ms, the speed setpoint of the drive is internally driven down a 10 ms ramp to 0V. The 3% region of actual speed is scaled to  $V_{LIM}$ .



**Note:** The set and release times of the holding brake vary with the servo motor and thus must be considered when setting parameters.

*Continued on next page*

---

## Power Wiring, continued

---



### WARNING!

### IMPACT HAZARD

The off-the-shelf configuration of the holding-brake function does not ensure the safety of personnel. In order to make this function safe for personnel, a normally-open contact and a user-installed suppressor device (varistor) must be incorporated into the brake circuit as shown in the following diagram.

**Failure to observe this precaution can result in severe injury or equipment damage.**

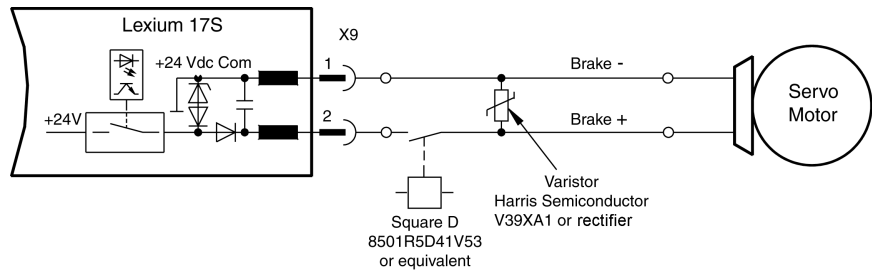

# Signal Wiring

## Lexium BPH Resolver Connection (excluded BPH055)



The following diagram shows the connections between the resolver and the 17S drive.

**Note:** The standard Lexium BPH series servo motors are equipped with two-pole, integral resolvers. The thermistor contact in the servo motor is connected via the resolver cable to the 17S drive.

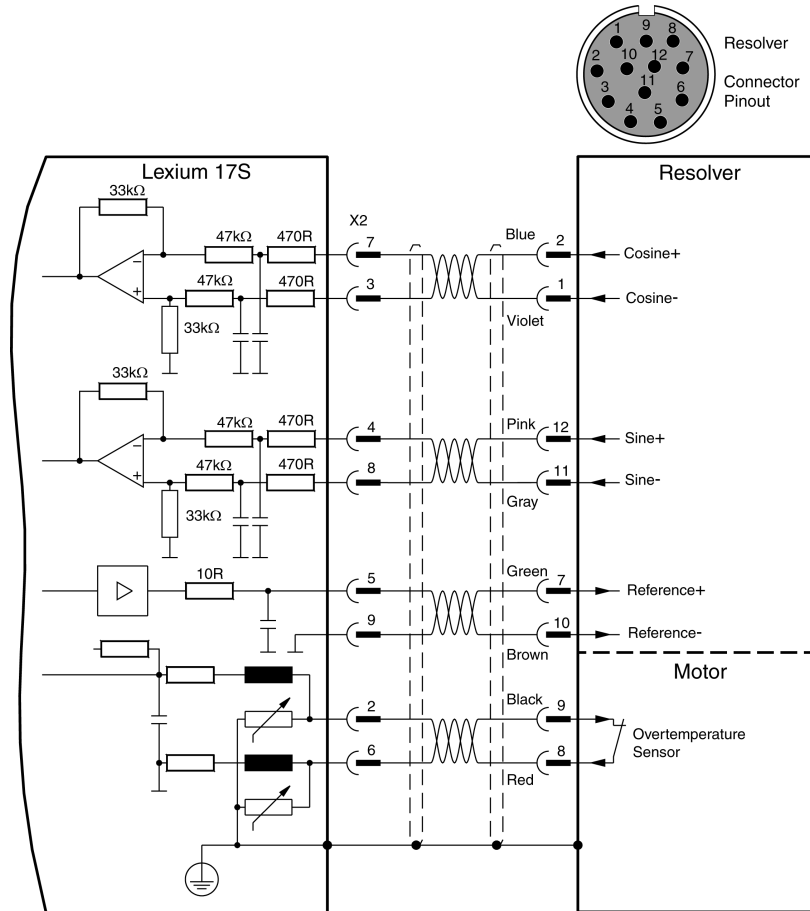

*Continued on next page*

## Signal Wiring, continued

### Lexium BPH055 Resolver Connection

The following diagram shows the connections between the resolver and the 17S drive.



**Note:** The BPH055 servo motors are equipped with two-pole, integral resolvers. The thermistor contact in the servo motor is connected via the resolver cable to the 17S drive.

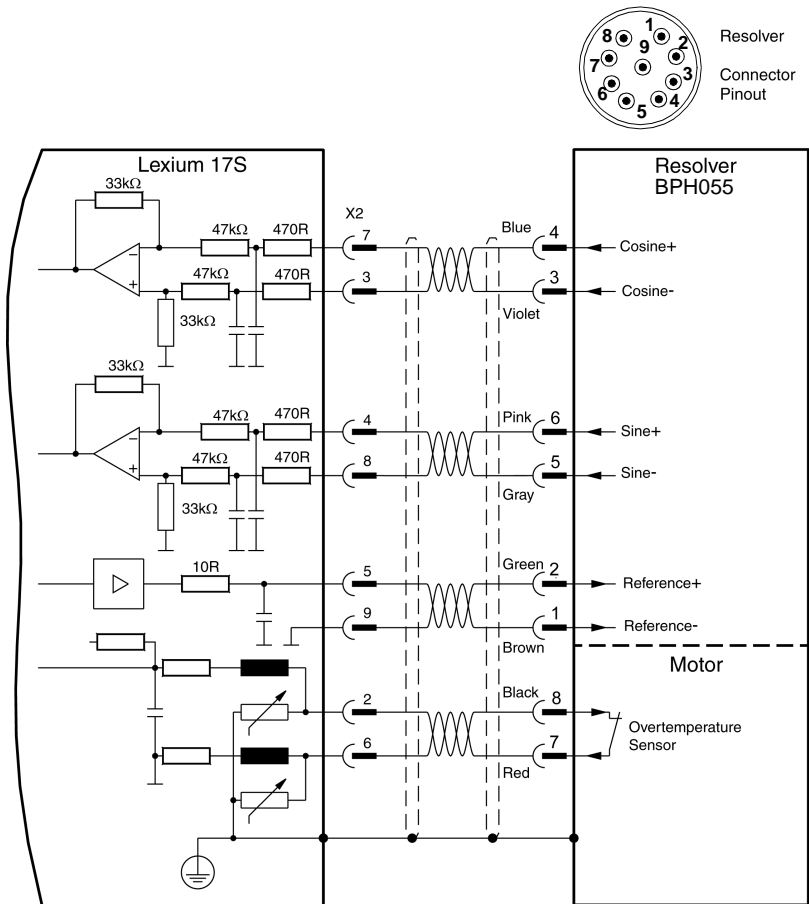

*Continued on next page*

## Signal Wiring, continued

### Encoder Input Connection

The following diagram shows the encoder input connections between the encoder and the 17S drive.



**Note:** The BPH series servo motors can be optionally fitted with a single-turn or multi-turn sine-cosine encoder, which is used by the 17S drive as the primary feedback device for operations requiring highly precise positioning or extremely smooth running. In addition, the thermistor contact in the servo motor is connected via the encoder cable to the 17S drive.

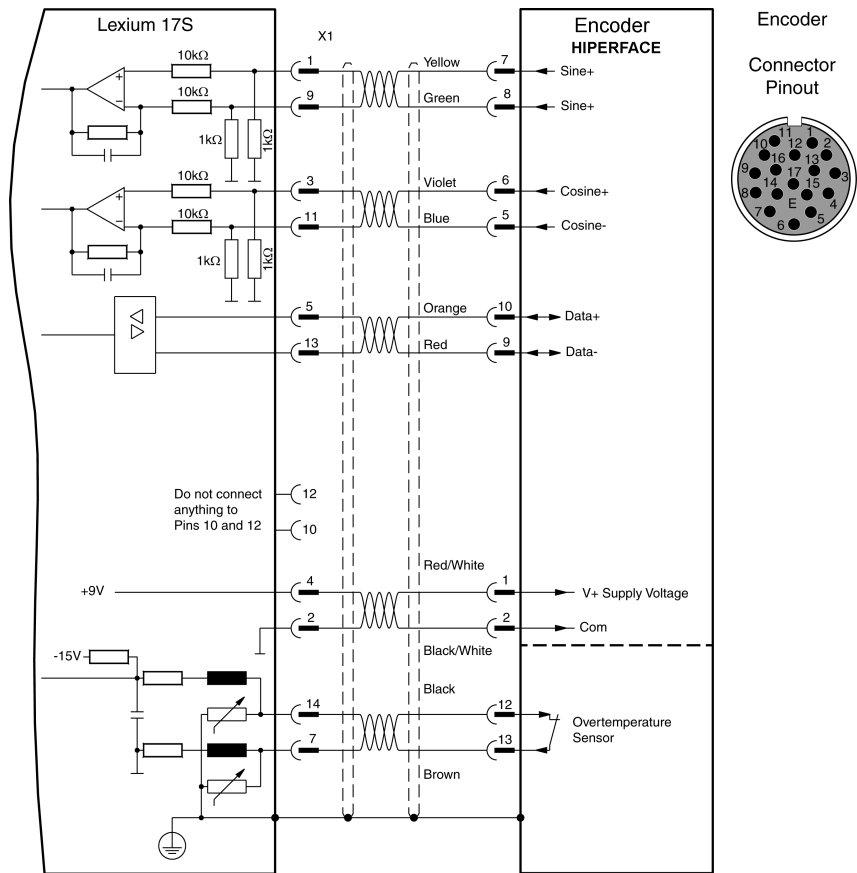

*Continued on next page*

---

## Signal Wiring, continued

---

### Auxiliary Encoder Interface

- **Master-slave Operation of Drives Diagram.**

The encoder interface can be used to link one or more drives together in a master-slave operation, as shown in the following diagram. Up to 16 slave drives can be controlled by a designated master drive via the encoder output. The UniLink software allows you to setup the parameters for the slave drive(s) and to adjust the gear ratio (number of pulses/turn).



**Note:** In this configuration, the analog setpoint inputs are disabled and Analog Com and I/O Com (connector X3) must be connected.

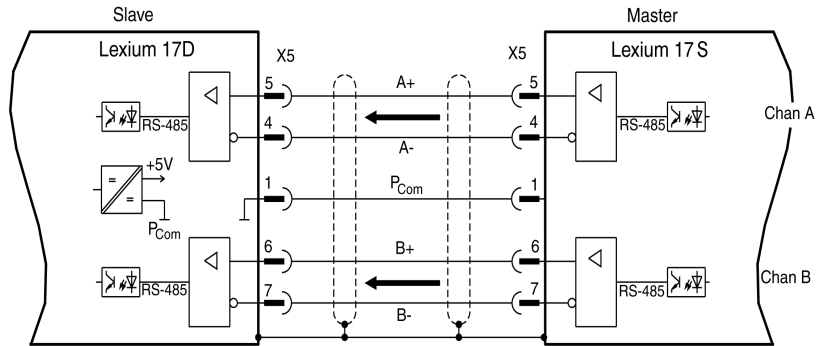



---

## Signal Wiring, continued

---

- **Incremental-Encoder Input Connection.**

The following diagram shows the incremental encoder input connections between the 17 drive and an external incremental encoder.

 **Note:** The receivers are supplied from an internal supply voltage.  
P<sub>Com</sub> must always be connected to the encoder ground.  
Incremental encoder is powered by an external Power Supply.

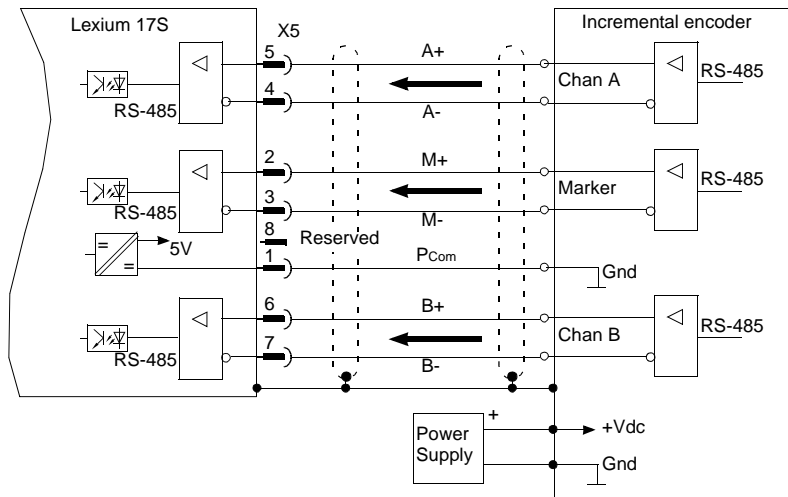

---

## Signal Wiring, continued

---

- **SSI Encoder Input Connection:**

The following diagram shows the connections between an external SSI encoder and the drive.

-  **Note:** The drivers are supplied from an internal supply voltage. P<sub>Com</sub> must always be connected to the encoder ground. SSI encoder is powered by an external Power Supply

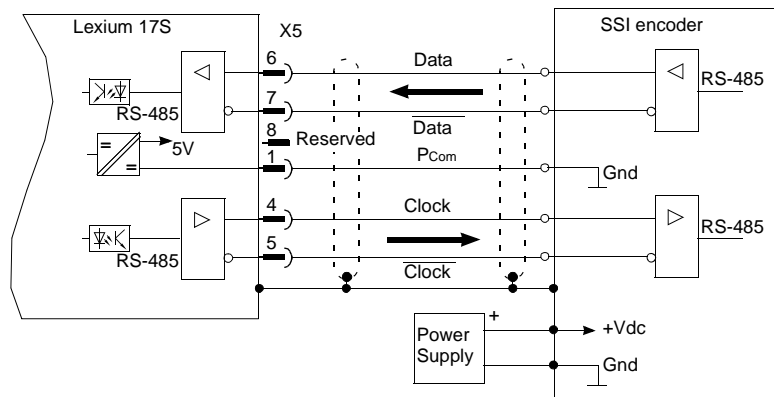

---

## Analog Input Connection

---

### Analog Inputs

The following diagram shows the connections between the two fully programmable, differential analog inputs on the 17S drive and a user device. (Refer to the list of pre-programmed functions contained in the UniLink online help.)

 **Note:** The Analog Com must always be connected to the user device Com as a ground reference.

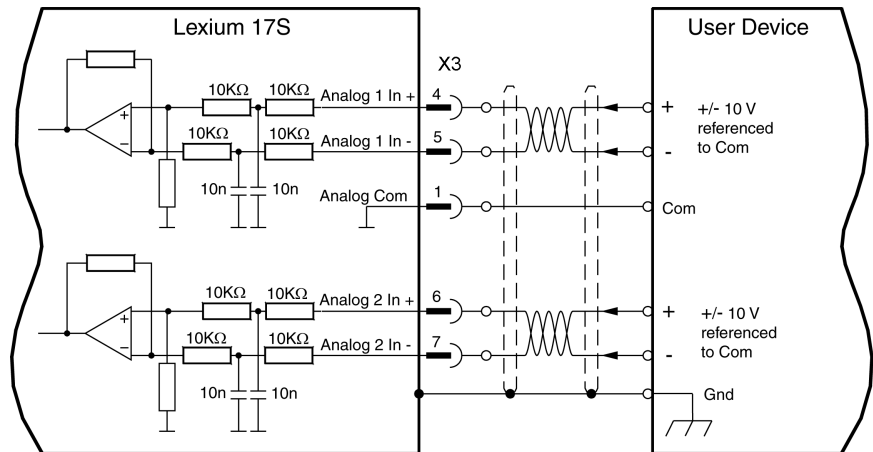

## Fault Relay and Digital I/O Connection

### Digital Inputs and Outputs

The following diagram shows the connections between the fault relay, the four fully-programmable, digital inputs, dedicated enable input and two digital outputs on the 17S drive and typical user devices. (A list of pre-programmed functions is contained in the UniLink online help.)

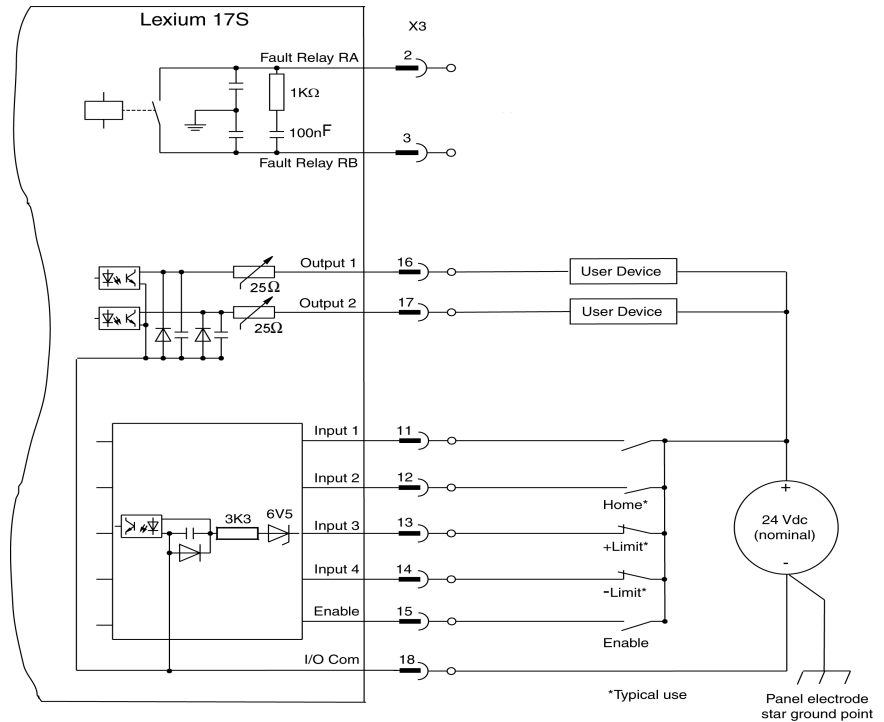

*Continued on next page*

---

## Fault Relay and Digital I/O Connection, continued

---

### Using Functions Pre-programmed into the Drive

**Fault Relay**- The isolated fault relay contacts are closed during normal operation and open when a fault condition exists. The relay state is not affected by the enable signal, I<sup>2</sup>t limit or warnings. All faults cause the Fault RA/RB contact to open and the switch-off of the output stage. A list of error messages can be found in chapter Troubleshooting.

**Digital Inputs 1, 2, 3 and 4** - You can use the four digital inputs to initiate pre-programmed functions that are stored in the drive.

**Digital Outputs 1 and 2** - You can use the two digital outputs to send messages from pre-programmed functions that are stored in the drive.

**Enable Input** - This is a dedicated, level-sensitive (as opposed to edge-sensitive) hardware input which will enable the output stage of the drive when 24 Vdc is applied and no fault conditions exist.



**Note:** The hardware enable is powered up upon detection of state sense versus transition sensitivity. Refer to the UniLink on-line help for software enable information.

---

---

## Serial Communications Connection

---

### RS-232 Null Modem Type Connection Diagram

The following diagram depicts the RS-232 communication connection between the Lexium 17S and a PC.

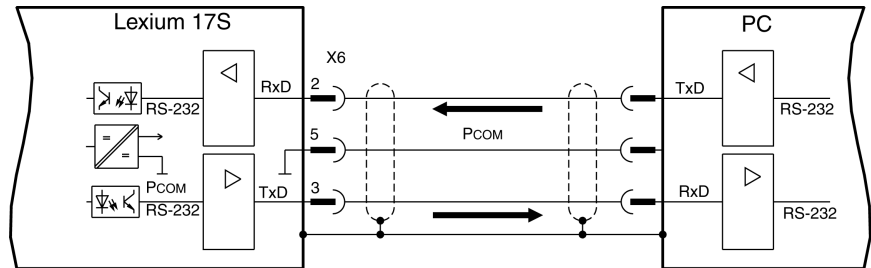

*See wiring in Appendix C*

The setting of the operating, position control, and motion-block parameters can be carried out with an ordinary commercial PC.

Connect the PC interface (X6) of the servo amplifier **while the supply to the equipment is switched off** via a normal commercial 3-core cable to a serial interface on the PC. **Do not use a null-modem link cable!**

The interface is electrically isolated through an optocoupler, and is at the same potential as the CANopen interface.

---

---

# System Operation



# 5

---

## At a Glance

### What's in this Chapter

This chapter provides information on operating the Lexium 17S series servo drives and includes the following topics:

Topic	Page
Powering up and powering down the system	68
Procedure for verifying system operation	71
Front panel controls and indicators	73

---

## Powering Up and Powering Down the System

---

### Power-on and Power-off Characteristics

The following diagram illustrates the functional sequence that occurs when the drive is turned on and off.

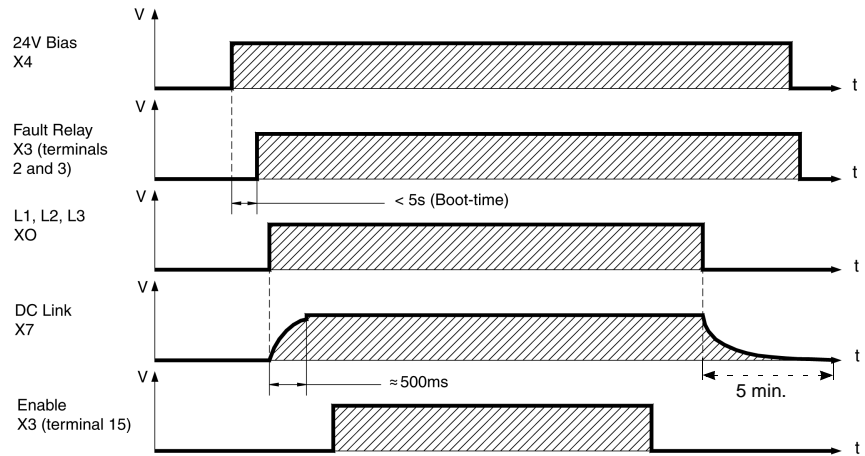



---

## Powering Up and Powering Down the System

---

### Stop Function

If a fault occurs the output stage of the servo amplifier is switched off and the Fault RA/RB contact is opened. In addition, a global error signal can be given out at one of the digital outputs (terminals X3/16 and X3/17). These signals can be used by the higher-level control to finish the current PLC cycle or to shut down the drive (with additional brake or similar.).

Instruments which are equipped with a selected "Brake" function use a special sequence for switching off the output stage.

The Stop functions are defined in EN 60204 (VDE 0113), Para. 9.2.2, 9.2.5.3.

There are three categories of Stop functions:

- Category 0: Shut down by immediately switching off the supply of energy to the drive machinery (i.e an uncontrolled shut-down);
- Category 1: A controlled shut-down, during which the supply of energy to the drive machinery is maintained to perform the shut-down, and where the energy supply is only interrupted when the shut-down has been completed;
- Category 2: A controlled shut-down, where the supply of energy to the drive machinery is maintained.

Every machine must be equipped with a Stop function to Category 0. Stop functions to Categories 1 and/or 2 must be provided if the safety or functional requirements of the machine make this necessary.

---

### Emergency Stop strategies

The Emergency Stop function is defined in EN 60204 (VDE 0113), Para. 9.2.5.4.

Implementation of the Emergency Stop function:

- Category 0: The controller is switched to "disable", the electrical supply (400VAC) is disconnected.  
The motor must be held by an electromagnetic holding device (brake).  
In multi-axis systems with connected DC-link bus (intermediate circuit) the motor leads have to be disconnected by a changeover switch and short-circuited by resistors connected in a star configuration.
  - Category 1: If hazardous conditions can result from an emergency stop switch-off with an unbraked run-down, then the drive can be switched off by a controlled shut-down.  
Stop Category 1 permits electromotive braking with a switch-off when zero speed has been reached. Safe shut-down can be achieved, when the loss of the mains supply is not rated as a fault and the control takes over the disabling of the servo amplifier.  
In the normal situation, only the supply power is switched off in a safe manner.  
The 24V auxiliary supply remains switched on.
-



---

## Procedure for Verifying System Operation

---

### Overview

The following procedure and associated information verifies operation of the system without creating a hazard to personnel or jeopardizing the equipment.



**Note:** Default parameters for each Lexium BPH series motor are loaded into your drive at the factory and contain valid and safe values for the current and speed controllers. A database for the servo motor parameters is stored in the drive. During commissioning, you must select the data set for the connected servo motor and store it in the drive. For most applications, these settings will provide good servo loop efficiency. For a description of all parameters and motor tuning, see the UniLink online help.

---

### Quick Tuning Procedure

This procedure will enable you to rapidly assess the operational readiness of the system.



Step	Action
1	<p>Disconnect the drive from the power source.</p> <p><b>WARNING!</b></p> <p><b>MECHANICAL MOVEMENT HAZARD</b></p> <p>Ensure the motor is securely mounted and that the load is disconnected from the motor.</p> <p><b>Failure to observe this precaution can result in severe injury or equipment damage.</b></p>
2	Ensure 0 V is applied to the enable input (connector X3, terminal 15).
3	Connect the PC to the drive via the serial communications cable.
4	Turn on the 24 Vdc bias supply. After the initialization procedure (< 5 seconds) the status is shown in the LED display.
5	Switch on the PC, start the UniLink software and select the serial communication port to which the drive is connected. (The parameters that are stored in the SRAM of the drive are transferred to the PC.)

---

*Continued on next page*

## Procedure for Verifying System Operation, continued

### Quick Tuning Procedure, continued

Step	Action
6	<p>Use the UniLink software to check/establish the following:</p> <ul style="list-style-type: none"> <li>● <b>Drive Parameters</b> - Set/restore the drive parameters to the factory default values.</li> <li>● <b>Supply voltage</b> - Set the supply voltage to the actual mains supply voltage.</li> <li>● <b>Servo Motor</b> - Select the applicable BPH servo motor.</li> <li>● <b>Feedback</b> - Ensure the feedback matches the feedback unit in the servo motor.</li> </ul>
7	<p>Check safety devices such as hardware limit switches, emergency stop circuitry and so forth.</p> <p> <b>WARNING!</b> <b>MECHANICAL MOVEMENT HAZARD</b></p> <p>Ensure personnel, tools and all other obstructions are clear of the equipment.</p> <p><b>Failure to observe this precaution can result in severe injury or equipment damage.</b></p>
8	Turn on the AC mains power supply.
9	Enable 24 Vdc on connector X3, terminal 15. Observe that 500 ms after the power supply was switched on, the servo motor is motionless with a standstill torque of $M_0$ .
10	<p>Using the UniLink Oscilloscope Service Function, program a small 50-rpm velocity command. If the servo motor oscillates, the Kp parameter in the "speed controller" menu page must be adjusted.</p> <p> <b>Note:</b> The Kp parameter may have to be adjusted after connecting the load. Refer to UniLink on-line help for more tuning information.</p>

 **Note:** The hardware enable is powered up upon detection of state sense versus transition sensitivity.

---

## Front Panel Controls and Indicators

---

### Keypad Operation

The operation of the keypad on the front panel of the 17S drive is described in the following table. The two keys can be used (as an alternative to using the PC) to specify and enter the SERCOS address for the drive.

Key	Function
▲	<b>Press once:</b> Increments address by 1 <b>Press twice in rapid succession:</b> Increments address by 10
▼	<b>Press once:</b> Decrements address by 1 <b>Press twice in rapid succession:</b> Decrements address by 10
▲▼	<b>Press and hold right key, then press left key:</b> Enters the address specified above.



**Note:** The drive must be powered down then powered up again to confirm an address change.

---

### LED Display

The alphanumeric display indicates drive power status conditions, error codes and warning codes. The power status conditions are shown below; error and warning codes are identified and described in the Troubleshooting chapter.

Status 1: 24 Vdc switched on. Displays the firmware version then after 1 second displays Status 2, 3 or 4.

Status 2: 24 Vdc switched on. Displays the continuous current rating of the drive; in this case, 1A. (Dot will be flashing.)

Status 3: 24 Vdc and mains supply switched on. (Dot will be flashing.)

Status 4: 24 Vdc and mains supply switched on and drive enabled. (Dot will be flashing.)

---

*Continued on next page*

---

## Front Panel Controls and Indicators, continued

---

### **SERCOS Communication LED Indicators**

The following illustration shows the location of the three SERCOS communication LED indicators on the SERCOS communication card at the top of the drive. The Rec\_T and Tra\_T LEDs are green and (when illuminated) respectively indicate information is being received or transmitted. The Error LED is red and illuminates when a SERCOS communication error occurs.



---

# Troubleshooting



---

## At a Glance

### What's in this Chapter

This chapter provides information on correcting problems with the 17S drive and contains the following topics:

Topic	Page
Warning messages	76
Error messages	77
Troubleshooting	81

## Warning Messages

### Warning Identification and Description

A warning is generated when a non-fatal fault occurs. Non-fatal faults allow the drive to remain enabled and the fault relay contact to remain closed. Either of the programmable digital outputs can be programmed to indicate that a warning condition has been detected. The cause of the warning is presented as an alphanumeric code on the drive's front panel LED display; these warning codes are identified and described in the following table.

Warning Code	Designation	Explanation
n01	I <sup>2</sup> t warning	Current threshold set by "I <sup>2</sup> t Message" parameter was exceeded.
n02	Regen power	Power threshold set by "Max Regen Power" parameter was exceeded.
n03	Following Fault	Following error threshold set by "Following Error" parameter was exceeded.
n04	Response monitoring	Response monitoring (fieldbus) is active.
n05	Mains phase	Mains phase missing. Can be disabled for single phase operation with the "Mains Phase Missing" parameter.
n06	Sw limit-switch 1	Passed software limit-switch 1.
n07	Sw limit-switch 2	Passed software limit-switch 2.
n08	Motion task error	A faulty motion task was started.
n09	No "Home" reference point	Motion task started with no "Home" reference point set.
n10	Positive Limit	Positive limit-switch activated.
n11	Negative Limit	Negative limit-switch activated.
n12	Default values	Only HIPERFACE®: motor default values loaded.
n13	SERCOS interface	SERCOS interface not functioning correctly.
n14	HIPERFACE®-reference mode	Attempt to reset while HIPERFACE®-reference mode was active.
n15	Table error	Velocity current table INXMODE 35 error
n16 ... n31	Reserved	reserved
n32	Firmware beta version	The firmware is not a released beta version
A	Reset	RESET is active at DIGITAL IN x



---

## Error Messages

---

### Error Identification and Description

Errors are generated when a fatal fault occurs. Fatal faults cause the drive to be disabled, the brake (if installed) to be activated and the fault relay contacts to open. Either of the programmable digital outputs can also be programmed to indicate that an error has been detected. The cause of the error is presented as an alphanumeric code on the drive's front panel LED display; these error codes are identified and described in the following table.

Error Code	Error (Fault)	Possible Cause/Corrective Action
F01	Drive heat sink overtemperature.	<ul style="list-style-type: none"><li>- Improve ventilation.</li><li>- Reduce motion profile duty cycle.</li></ul>
F02	DC link voltage limit exceeded.	<ul style="list-style-type: none"><li>- Check Parameter "Mains Supply Voltage" for correct setting.</li><li>- Supply voltage too high; use a mains transformer.</li><li>- Regen power limit was exceeded; adjust motion profile or install larger regen resistor.</li></ul>
F03	Following error limit exceeded.	<ul style="list-style-type: none"><li>- Increase <math>I_{rms}</math> or <math>I_{peak}</math> (keep within motor operating range).</li><li>- SW ramp parameters set too large.</li></ul>
F04	Feedback signals missing or incorrect.	<ul style="list-style-type: none"><li>- Defective feedback device.</li><li>- Check for correct device type selected in "Feedback Type" parameter.</li><li>- Check feedback cable and connections.</li></ul>
F05	DC-link voltage less than factory preset (100V).	Supply voltage not present or too low when drive was enabled. Only enable the drive when the mains supply voltage has been on longer than 500 ms.

---

*Continued on next page*

---

## Error Messages, continued

---

### Error Identification and Description, continued

Error Code	Error (Fault)	Possible Cause/Corrective Action
F06	Motor overtemperature.	<ul style="list-style-type: none"><li>- <math>I_{rms}</math> or <math>I_{peak}</math> set too high.</li><li>- Defective motor</li><li>- If motor is not hot, check feedback cables and connectors.</li><li>- Reduce motion profile duty cycle</li><li>- Improve ventilation of the motor</li></ul>
F07	Internal 24 Vdc fault.	Return drive to manufacturer
F08	Motor speed limit exceeded.	<ul style="list-style-type: none"><li>- Feedback parameters not set correctly.</li><li>- Incorrect feedback wiring.</li><li>- Motor phases reversed.</li><li>- Check Parameter "Overspeed" for correct setting.</li></ul>
F09	EEPROM checksum error.	Return drive to manufacturer.
F10	Flash-EPROM checksum error.	Return drive to manufacturer.
F11	Motor brake fault.	<ul style="list-style-type: none"><li>- Brake parameter set to "WITH" when brake does not exist.</li><li>- Defective brake.</li><li>- Check motor power cable and connections.</li></ul>
F12	Motor phase missing.	<ul style="list-style-type: none"><li>- Defective motor.</li><li>- Check motor power cable and connections</li></ul>
F13	Drive internal temperature exceeded.	<ul style="list-style-type: none"><li>- Improve ventilation.</li><li>- Reduce motion profile duty cycle.</li></ul>

---

*Continued on next page*

## Error Messages, continued

### Error Identification and Description, continued

Error Code	Error (Fault)	Possible Cause/Corrective Action
F14	Drive output stage fault.	<ul style="list-style-type: none"> <li>- Check motor cable for damage or shorts.</li> <li>- Output module is overheated; improve ventilation.</li> <li>- Short-circuit or short to ground in the external Regen resistor.</li> <li>- Motor has short-circuit/ground short; replace motor.</li> <li>- Output stage is faulty; return drive to manufacturer.</li> </ul>
F15	I <sup>2</sup> t maximum value exceeded.	<ul style="list-style-type: none"> <li>- I<sub>rms</sub> or I<sub>peak</sub> set incorrectly.</li> <li>- Reduce motion profile duty cycle.</li> </ul>
F16	Mains supply missing two or three phases.	<ul style="list-style-type: none"> <li>- Check mains fuses.</li> <li>- Check mains wiring and connections on drive.</li> </ul>
F17	A/D converter error.	Return drive to manufacturer
F18	Regen circuit faulty or incorrect setting.	<ul style="list-style-type: none"> <li>- Check jumper on X8 if using internal regen resistor.</li> <li>- Check wiring of external regen resistor if used.</li> <li>- Check fuses of external regen resistor.</li> </ul>
F19	Mains supply missing one phase.	<ul style="list-style-type: none"> <li>- For single phase operation, set "Phase Missing" parameter to "no message".</li> <li>- Check mains supply fuses.</li> <li>- Check mains connector on drive.</li> <li>- Check mains supply wiring.</li> </ul>
F20	Slot fault	Hardware fault of the expansion card
F21	Handling fault	Software fault of the expansion card
F22	Reserved	Reserved
F23	Reserved	Reserved
F24	Reserved	Reserved
F25	Commutation error	Encoder system only

---

<b>Error Code</b>	<b>Error (Fault)</b>	<b>Possible Cause/Corrective Action</b>
F26	Reserved	Reserved
F27	Reserved	Reserved
F28	Reserved	Reserved
F29	SERCOS error	SERCOS systems only
F30	SERCOS time out	SERCOS systems only
F31	Reserved	Reserved
F32	System error	System software not responding correctly, return drive to manufacturer.

---

---

## Troubleshooting

---

### Problems, Possible Causes and Corrective Actions

The following table identifies some common system problems, their possible causes and recommended corrective actions. However, the configuration of your installation may create other reasons, and consequently other corrections, for the problem.

Problem	Possible Causes	Corrective Actions
No communication with PC	<ul style="list-style-type: none"> <li>- Wrong cable used.</li> <li>- Cable plugged into wrong position in drive or PC.</li> <li>- Wrong PC interface selected.</li> </ul>	<ul style="list-style-type: none"> <li>- Check cable.</li> <li>- Plug cable into the correct sockets on the drive and PC.</li> <li>- Select correct interface.</li> </ul>
Motor does not rotate	<ul style="list-style-type: none"> <li>- Drive not enabled.</li> <li>- Break in SERCOS fiber optic cable.</li> <li>- Motor phases swapped.</li> <li>- Brake not released.</li> <li>- Motor is mechanically blocked.</li> <li>- Motor pole number set incorrectly.</li> <li>- Feedback set up incorrectly.</li> </ul>	<ul style="list-style-type: none"> <li>- Apply enable signal</li> <li>- Check cable</li> <li>- Correct motor phase sequence</li> <li>- Check brake control</li> <li>- Check mechanism</li> <li>- Set motor pole number.</li> <li>- Set up feedback correctly.</li> </ul>

*Continued on next page*

---

## Troubleshooting, continued

---

**Problems,  
Possible Causes  
and Corrective  
Actions,  
continued**

<b>Problem</b>	<b>Possible Causes</b>	<b>Corrective Actions</b>
Motor oscillates	<ul style="list-style-type: none"><li>- Gain too high (speed controller).</li><li>- Shielding in feedback cable has a break.</li></ul>	<ul style="list-style-type: none"><li>- Reduce Kp (speed controller).</li><li>- Replace feedback cable.</li></ul>
Poor drive performance (drive too soft)	<ul style="list-style-type: none"><li>- Kp (speed controller) too low.</li><li>- Tn (speed controller) too high.</li><li>- PID-T2 too high.</li><li>- T-Tacho too high.</li></ul>	<ul style="list-style-type: none"><li>- Increase Kp (speed controller).</li><li>- Use motor default value for Tn (speed controller).</li><li>- Reduce PID-T2.</li><li>- Reduce T-Tacho.</li></ul>
Motor runs roughly	<ul style="list-style-type: none"><li>- Kp (speed controller) too high.</li><li>- Tn (speed controller) too low.</li><li>- PID-T2 too low.</li><li>- T-Tacho too low.</li></ul>	<ul style="list-style-type: none"><li>- Reduce Kp (speed controller).</li><li>- Use motor default value for Tn (speed controller).</li><li>- Increase PID-T2.</li><li>- Increase T-Tacho.</li></ul>

---

---

# Specifications



---

## At a Glance

### What's in this Appendix

This appendix contains the following topics.

Topic	Page
Performance specifications	84
Environmental and mechanical specifications	85
Electrical specifications	87
Wire specifications (recommended)	99

---

---

## Performance Specifications

---

### Performance Specifications Table

The following table lists 17S performance specifications.

PERFORMANCE		
Servo updates	Torque	62.5 $\mu$ s
	Velocity	250 $\mu$ s
	Position	250 $\mu$ s
Tuning procedure	UniLink application*	
* Included in AMOCSW001V•00 (CD-ROM)		

---



## Environmental and Mechanical Specifications

### Environmental Specifications Table

The following table provides 17S environmental specifications.

ENVIRONMENTAL		
Storage	High temperature, non-operating	+70°C maximum
	Low temperature, non-operating	-25°C minimum
Humidity	Non-operating	95% RH maximum, non-condensing
	Operating	85% RH maximum, non-condensing
Operating temperature (ambient measured at fan inlet)	Full power	0 ... 45°C
	With linear derating 2,5% / °C (available power: 75% of rated output at 55°C)	45 ... 55°C max
Vibration (operational)	10 ... 57 Hz	Sinusoidal, 0.75 mm amplitude
	57 ... 150 Hz	1.0 g
Air pressure	Operating:	
	Full power	1000 m (90 kPa)
	With linear derating 1,5% / 100m (available power: 75% of rated output at 2500m)	1000 ... 2500m (73kPa) max
	Transport	57 kPa (4540 m)
Contaminants	Pollution degree 2, as defined in EN60204/EN50178	
Cooling	Models: MHDS1004N00 MHDS1008N00 MHDS1017N00 MHDS1028N00 MHDS1056N00	Integrated heatsink with internal fan.

Continued on next page

---

## Environmental and Mechanical Specifications, continued

---

### Mechanical Specifications Table

The following table provides 17S mechanical specifications.

Drive Model Number	Height	Width	Depth	Weight
MHDS1004N00	325 mm	70 mm	265 mm	2.5 kg
MHDS1008N00				
MHDS1017N00				
MHDS1028N00				
MHDS1056N00	325 mm	120 mm	265 mm	3.0 kg

---

---

# Electrical Specifications

---

**What's in this Section**

This section provides tables for the following topics.

<b>Topic</b>	<b>Page</b>
Electrical Specifications - Power	88
Electrical Specifications - Regen resistor	92
Electrical Specifications - Signal	93

---

---

## Electrical Specifications - Power

---

### Line Input Specifications Table

The following table provides 17S line input specifications.

LINE INPUT		
Voltage	208 Vac -10% 60 Hz, 230 Vac -10% 50 Hz. 480 Vac +10%, 50 - 60 Hz, three-phase*	
Current	MHDS1004N00	1.8 A RMS**
	MHDS1008N00	3.6 A RMS
	MHDS1017N00	7.2 A RMS
	MHDS1028N00	12 A RMS
	MHDS1056N00	24 A RMS
Inrush current	Internally limited	
Efficiency	Greater than 98%	
* Read carefully "Electrical considerations"		
** Single-phase operation permitted.		

---

*Continued on next page*

---

## Electrical Specifications - Power, continued

---

### Bias Input Specifications Table

The following table provides 17S bias input specifications.

Motor Brake Present	Bias Input	Value
No	Voltage	20 ... 30 Vdc
	Current	0.75 A to 1.2 A
Yes	Voltage	24 Vdc -10%, +5%
	Current	3 A max.



**Note:** The bias input also provides power to the optional motor brake.

---

### External Fuse Specifications Table

The following table provides 17S external fuse specifications.

Input Type	Model Number	Fuse
Line	MHDS1004N00	6 A, time delay
	MHDS1008N00	
	MHDS1017N00	10 A, time delay
	MHDS1028N00	
	MHDS1056N00	20 A, time delay
Optional external Regen	MHDS1004N00	4 A, fast acting*
	MHDS1008N00	
	MHDS1017N00	6 A, fast acting*
	MHDS1028N00	
	MHDS1056N00	
*Two fuses in series, >= 500 V, dimensions: 10 x 38.		

*Continued on next page*

---

## Electrical Specifications - Power, continued

### Motor Output Specifications Table

The following table provides 17S motor output specifications.

Parameter	Type	Model Number	Current
Output current (RMS)	Continuous	MHDS1004N00*	1.5 A
		MHDS1008N00	3 A
		MHDS1017N00	6 A
		MHDS1028N00	10 A
		MHDS1056N00	20 A
	Intermittent**	MHDS1004N00	3 A
		MHDS1008N00	6 A
		MHDS1017N00	12 A
		MHDS1028N00	20 A
		MHDS1056N00	40 A
Switching frequency	8 kHz $\pm$ 0.1%		
Cable length***	75 m (maximum)		
Maximum cable capacitance (motor phase to ground or shield)	150 pF/m		
* For single phase main connection, the output current is limited to the output current specified above or 4 amps, whichever is lower. ** Duration depends on settings in Unilink. *** Cable lengths exceeding 25 m require the use of motor choke AM0FIL001V056			



**Note:** Motors must be compatible with following table:

Motor Inductance:		
Model	Min (mH)	Max (mH)
MHDS1004N00	16	400
MHDS1008N00	8	200
MHDS1017N00	4	100
MHDS1028N00	3.5	60
MHDS1056N00	1.5	30

*Continued on next page*

---

## Electrical Specifications - Power, continued

---

### Internal Power Dissipation Specifications Table

The following table provides 17S internal power dissipation at maximum continuous output power. This information may be useful to size the thermal capability of the mounting cabinet.

Model Number	Power
MHDS1004N00	30 W
MHDS1008N00	40 W
MHDS1017N00	60 W
MHDS1028N00	90 W
MHDS1056N00	200 W



**Note:** These power dissipations are measured at maximum continuous power and should be considered worst case. Often in sizing servo systems, factors such as profile duty cycle may reduce these numbers. These values do not include power dissipated in the Regen resistor. This is application-specific and must be calculated separately.

Quiescent dissipation when output stage is disabled is 15 W

---

## Electrical Specifications - Regen Resistor

### Regen Circuit Specifications

The following table provides technical data on the Regen circuit.

Parameter		Rated data	Units	Model Number (prefix with MHDS10)	
				04N00 08N00	17N00 28N00 56N00
Supply Voltage	3 phase, 230 V	Upper switch-on level of Regen circuit	V	400 - 430	
		Switch-off level of Regen circuit	V	380 - 410	
		Continuous power of Regen circuit (RBint)	W	80	200
		Continuous power of Regen circuit (RBext) maximum.	kW	0.25	0.75
		Pulse power, internal (RBint max. 1s)	kW	2.5	5
		Pulse power, external (RBext max. 1s)	kW	5	
	3 phase, 400 V	Upper switch-on level of Regen circuit	V	720 - 750	
		Switch-off level of Regen circuit	V	680 - 710	
		Continuous power of Regen circuit (RBint)	W	80	200
		Continuous power of Regen circuit (RBext) max.	kW	0.4	1.2
		Pulse power, internal (RBint max. 1s)	kW	8	16
		Pulse power, external (RBext max. 1s)	kW	16	
	3 phase, 480 V	Upper switch-on level of Regen circuit	V	840 - 870	
		Switch-off level of Regen circuit	V	800 - 830	
		Continuous power of Regen circuit (RBint)	W	80	200
		Continuous power of Regen circuit (RBext) maximum.	kW	0.5	1.5
		Pulse power, internal (RBint maximum 1s)	kW	10.5	21
		Pulse power, external (RBext maximum 1s)	kW	21	
External Regen resistor			Ω	33	
Internal Regen resistor			Ω	66	33



---

## Electrical Specifications - Signal

---

### Motor Overtemperature Input Specifications Table

The following table provides 17S motor overtemperature input specifications.

MOTOR OVERTEMPERATURE INPUT	
Thermistor	PTC will generate fault when resistance exceeds $290\Omega \pm 10\%$ * (default value)
Thermostat	Closed for normal operation
* The value of the threshold is adjustable by the parameter MAXTEMPM (see Unilink commands)	

---

### Resolver Input Specifications Table

The following table provides resolver input specifications.

RESOLVER	
Reference	8kHz $\pm$ 0.1%
Drive capability	35 mA RMS
Amplitude	4.75V RMS
Pair of poles	1 (default)
Resolution	14 bits (0.02°)
Accuracy	12 bits (0.09°)
Conversion method	Tracking
Resolver type	Transmit mode
Resolver transformation ratio	0.5
Loss of feedback	Detection circuit included
Maximum cable length	75 m
Maximum cable capacitance (signal connector to shield)	120 pF/m

---

## Electrical Specifications - Signal, continued

### Encoder Input Specifications Table

The following table provides 17S encoder input specifications

ENCODER INPUT				
Internal power supply	Voltage	9V ± 5%		
	Current (maximum)	200 ma		
Input Signal	Sin-Cos encoder (cyclic absolute)	Absolute accuracy	15 bits (39 arc-seconds or 0.01°)	
		Resolution	20 bits (1.2 arc-seconds or 0.0003°)	
	Sin-Cos encoder (multi-turn absolute)	Turn counter	12 bits	
		Absolute accuracy within one turn	15 bits (39 arc-seconds or 0.01°)	
		Resolution within one turn	20 bits (1.2 arc-seconds or 0.0003°)	

### Emulated Encoder Output (Incremental Format) Specifications Table

The following table provides 17S emulated encoder output (in incremental format) specifications.

EMULATED ENCODER OUTPUT (INCREMENTAL FORMAT)	
Channels	A, B, and Marker
Type	Differential, RS-485 compliant
Resolution with:	
Resolver feedback	512, 1024 line count; 1024/2048/4096 edges
Sin-Cos Encoder feedback	512/1024/2048/4096/8192/16384 line count

*Continued on next page*

## Electrical Specifications - Signal, continued

### Encoder Output (Incremental Format) Timing Diagram

The following diagram shows the timing for the encoder output (incremental format).

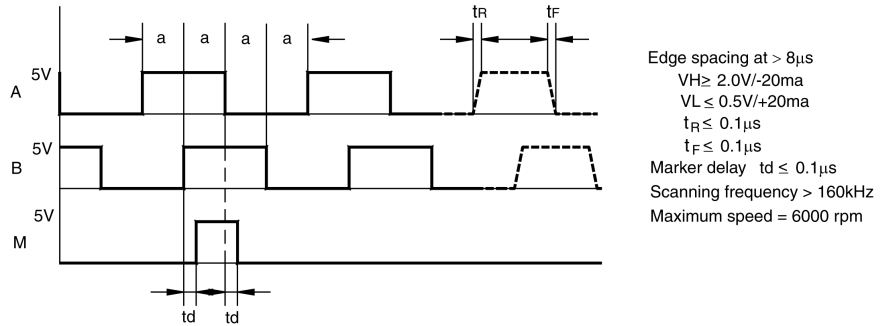

### Auxiliary Incremental Encoder Input Specifications Table

The following table provides 17D encoder input (slave) specifications.

ENCODER INPUT (SLAVE)	
Channels	A and B
Type	Differential, RS-485 compliant
Voltage	8 V nominal
Current	200 mA (maximum)
Maximum frequency	500 kHz
Rise time	$\leq 0.1 \mu\text{s}$
Fall time	$\leq 0.1 \mu\text{s}$

*Continued on next page*

---

## Electrical Specifications - Signal, continued

---

### Discrete Input Specifications Table

The following table provides 17S discrete input specifications.

DISCRETE INPUT	
Channels	Five (four programmable and one dedicated for enable)
Type	Solid state, optically isolated, compatible IEC 1131-2 type 1
Transient isolation voltage	250 Vac (channel to chassis)
$V_{IN}$ maximum	30 Vdc
$I_{IN}$ @ $V_{IN} = 24$ V	5 mA
$V_{IH}$ minimum	12 V (minimum input voltage to be recognized as high – true)
$V_{IL}$ maximum	7 V (maximum input voltage to be recognized as low – false)
Scan time:	
Normal	1 ms
High speed	< 50 $\mu$ s

### Discrete Output Specifications Table

The following table provides 17S discrete output specifications.

DISCRETE OUTPUT	
Channels	Two
Type	Solid state: open collector 30 Vdc max., optically isolated
Transient isolation voltage	250 Vac (channel to chassis)
Sense	True low, sinking
$I_{OUT}$	10 mA maximum
Protection	Yes (PTC resistor: 25 $\Omega$ )
Scan time	1 ms

---

*Continued on next page*

---

## Electrical Specifications - Signal, continued

---

### Fault Relay Output Specifications Table

The following table provides 17S fault relay output specifications.

FAULT RELAY OUTPUT	
Type	Relay contact
Sense	True (open)
V <sub>MAX</sub>	30 Vdc; 42 Vac
I <sub>OUT</sub>	500 mA resistive

---

### Brake Output Specifications Table

The following table provides 17S brake output specifications.

BRAKE OUTPUT	
V <sub>OUT</sub>	Internally connected to bias supply
I <sub>OUT</sub>	2 A (maximum)



**Note:** An external brake relay is required for cable lengths greater than 50 m.

---

*Continued on next page*

---

## Electrical Specifications - Signal, continued

---

### Analog Input Specifications Table

The following table lists the analog inputs specifications.

ANALOG INPUTS	
Channels	Two
Type	Differential, non-isolated
Maximum common mode voltage referenced to AGND	±10V
Measurement range	±10 Vdc
Maximum differential input	±12 V
Accuracy	12 bits
Resolution	Input 1 = 14 bits (±10V range) Input 2 = 12 bits (±10V range)
Input impedance	20 kΩ
Scan time	250 μs

---

### Serial Communications Specifications Table

The following table lists the serial communications specifications.

SERIAL I/O	
Data bits	Eight
Stop bits	One
Parity	None
Baud rate	9600

---

## Wire Specifications (Recommended)

### Wire Specifications

The following table lists the recommended wire specifications. Use only copper wire with insulation rated at 75°C or greater, unless otherwise specified.

Item	Drive Model No.	Wire Size	Notes
AC mains	MHDS1004N00 MHDS1008N00 MHDS1017N00 MHDS1028N00	1.5 mm <sup>2</sup> (14 AWG)	
	MHDS1056N00	4.0 mm <sup>2</sup> (12 AWG)	
Protective earth	All	4.0 mm <sup>2</sup> (12 AWG)	
DC Link	MHDS1004N00 MHDS1008N00 MHDS1017N00 MHDS1028N00	1.5 mm <sup>2</sup> (14 AWG)	Shielded for lengths greater than 20cm
	MHDS1056N00	4.0 mm <sup>2</sup> (12 AWG)	Shielded for lengths greater than 20cm
Analog signals	All	0.25 mm <sup>2</sup> (22 AWG) minimum	Twisted pairs, shielded
Digital I/O and Fault Relay	All	0.5 mm <sup>2</sup> (20 AWG) minimum	
Brake	All	1.0 mm <sup>2</sup> (18 AWG) minimum	Shielded
Bias power	All	2.5 mm <sup>2</sup> (14 AWG) maximum	
Optional external Regen resistor	All	1.5 mm <sup>2</sup> (14 AWG)	High temperature insulation (155°C or greater)

---



---

## Parts List



# B

---

### At a Glance

#### What's in this Appendix

This appendix contains information about the following Lexium 17S parts and assemblies.

Topic	Page
Lexium 17S drives	102
External 24Vdc supply	103
Drive cables	104
Optional external Regen resistor assemblies	106
Optional motor choke	107
Spare parts	108

---

---

## Lexium 17S Drives

---

**Drives Available** The Lexium 17S drives are available in five models according to different output current levels as identified in the following table.

<b>Model</b>	<b>Intermittent (Peak) Output Current</b>	<b>Continuous (RMS) Output Current</b>
MHDS1004N00	4.2 A	1.5 A
MHDS1008N00	8.4 A	3.0 A
MHDS1017N00	16.8 A	6.0 A
MHDS1028N00	28.0 A	10.0 A
MHDS1056N00	56.0 A	20.0 A

---

## External 24Vdc supply

### External 24Vdc supply

A reminder of the a 24 V consumption for the Lexium MHDA/MHDS servodrives with BHP motors is given below.

Lexium servodrive	MHD•1004/ 1008N00		MHD•1017N00		MHD•1028N00			MHD•1056N00	
Associated BPH motor	075•	095•	095•	115•	095•	115•	142•	142•	190•
Current without brake (A)	0.75	0.75	0.75	0.75	0.75	0.75	0.75	1.2	1.2
Current with brake (A)	1.25	1.45	1.45	1.55	1.45	1.55	1.75	2.2	2.7
Description	Output voltage		Rating		Parallel connection			Ref.	Weight
	V		A						Kg
<b>Module ~ 100...240 V 50/60 - 400 Hz and 125 Vdc</b>	24 Vdc SELV		1.1		Yes			<b>TSX SUP 1011</b> (1) (2)	0.720
<b>Module ~ 100...120 V and ~ 200...240V, 50/60 - 400 Hz</b>	24 Vdc SELV		2.2		Yes			<b>TSX SUP 1021</b> (1) (2)	1.090
			5		Yes			<b>TSX SUP 1051</b> (1) (2)	1.120
<b>Unit ~ 100...120V and ~ 200...240V, 50/60 - 400 Hz</b>	24 Vdc SELV		10		Yes			<b>TSX SUP 1101</b> (1)	2.100
(1) Product supplied as standard with a bilingual reference guide: French and English. (2) Mounted in Premium TSX RKY 6/8/12/6E/8E/12E racks (any slot except the slot for TSX PSY••0M power supply modules), on AM1-DE200/DP200 rails or on AM1-PA mounting plate.									

---

## Drive Cables

---

### Drive to Motor Cables

Consult the BPH motors manual for drive-to-motor cable part numbers and motor part numbers.

---

### RS-232 Serial Communications Cable Part Table

To connect the drive's serial interface port to your PC, use the following cable.

Part Number	Description
AM0CAV001V003	3 m cable

---

### Encoder Output Cable Parts Table

The following table lists encoder output cable for the Lexium 17S drive.

Part Number	Description
690MCI00206	6 m 17S to tinned leads

---

*Continued on next page*

---

## Drive Cables, continued

---

### Fiber Optic Cables Parts Table

The following table lists part numbers for SMA 1000 micron plastic SERCOS fiber optic cables. These cables range in length from 0.3...38 m. Each cable terminates with an SMA type connector.



#### CAUTION!

The minimum bend radius for these fiber optic cables is 25 mm (1 inch). Do NOT exceed this bend radius.

**Failure to stay within the 25 mm (1 inch) bend radius can result in damaged cables.**

The maximum tensile load during installation is 25 Kg/cable. Operating temperature is -40°C ... 80°C.

Part Number	Description	Length (m)
990MCO00001	1 ft cable	0.3
990MCO00003	3 ft cable	0.9
990MCO00005	5 ft cable	1.5
990MCO00015	15 ft cable	4.6
990MCO00025	25 ft cable	7.6
990MCO00035	35 ft cable	10.7
990MCO00045	45 ft cable	13.7
990MCO00055	55 ft cable	16.8
990MCO00065	65 ft cable	19.8
990MCO00075	75 ft cable	22.9
990MCO00085	85 ft cable	25.9
990MCO00095	95 ft cable	29
990MCO00105	105 ft cable	32
990MCO00115	115 ft cable	35
990MCO00125	125 ft cable	37.5
990MC100008	Bulk head connector	-

---

## Optional External Regen Resistor Assemblies

---

### Optional Regen Resistor Assembly Part Table

The following table identifies the optional external Regen resistor assemblies available for the Lexium 17S drive.

Part Number	Description
AM0RFE001V025	33Ω, 250 W, Regen resistor
AM0RFE001V050	33Ω, 500 W, Regen resistor
AM0RFE001V150	33Ω, 1,500 W, Regen resistor

---

---

## Optional Motor Choke

---

**Optional Motor  
Choke Part Table**

These following table identifies the servo motor choke available for the Lexium 17S drive.

Part Number	Description
AM0FIL001V056	Motor choke

---

---

## Spare Parts

---

### Spare Parts Table

These field-replaceable spare parts are available from Schneider.

Part Number	Description
AM0SPA001V000	17S Connector Kit: I/O connector 24 V connector DC Bus connector Regen resistor connector Mains supply connector

---



---

# Cable Connection Wiring Diagrams

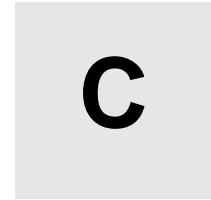

---

## At a Glance

### What's in this Appendix

This appendix provides procedures and diagrams that show you how to wire certain cable connectors that are used with the Lexium 17S drive.

This appendix presents the following topics.

Topic	Page
Wiring a Sub-D connector with shielding	110
Wiring up the motor power connector (drive end)	112
Serial communications interface connector (X6)	115

---

## Wiring a Sub-D Connector with Shielding

---

### Wiring the Sub-D Connector

If you construct your own Sub-D connector with shielding, please do so according to the following procedure which correlates to the eight steps in the diagram that follows this procedure.

Step	Action
1	Carefully remove about 25mm of the outer covering while taking care not to damage the braided shield.
2	Push the exposed braided shield back over the outer covering.
3	Leave the first 12mm of the braided shield free and insulate the rear portion with shrink tubing.
4	Carefully strip about 5mm from the individual wires while taking care not to damage the copper strands.
5	Verify pin assignments then solder the individual wires to the solder cups of the Sub-D connector. (Check the wire colors.)
6	Attach the cable to the connector housing strain relief; the strain relief must have good contact with the exposed shielding of the cable.
7	Place the knurled screws in position.
8	Place the Sub-D connector in the groove of the half-housing (pin 1 at bottom) and press the two halves together.  <b>Note:</b> Once the halves of the housing have been pressed together, they cannot be opened without damaging them.

---

*Continued on next page*

---

## Wiring a Sub-D Connector with Shielding, continued

---

### Sub-D Connector Diagram

The following diagram shows the eight steps required to wire a Sub-D connector with shielding.

#### Wiring a Sub-D Connector with Shielding

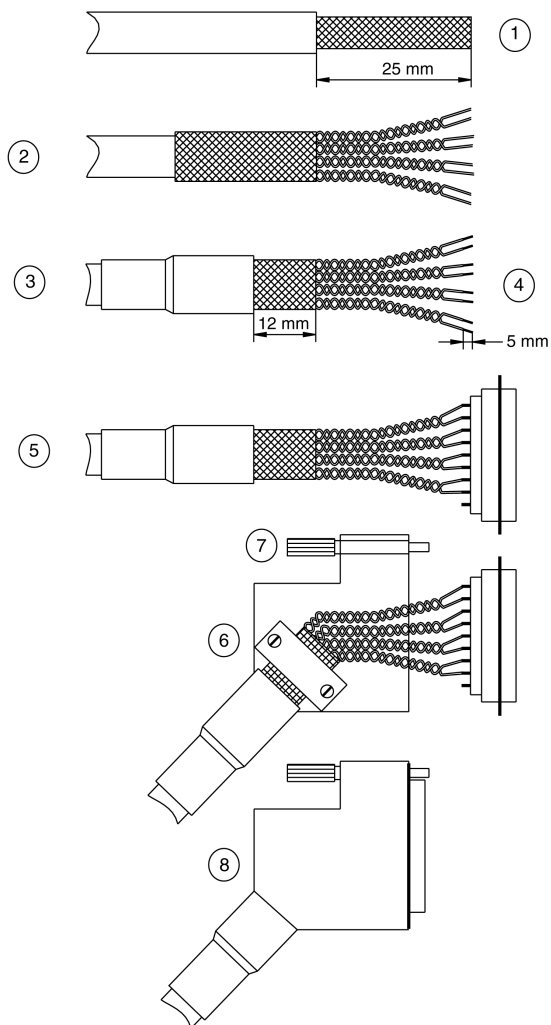

---

## Wiring the Motor Power Connector (Drive end)

---

### Wiring the Motor Power Connector

If you construct your own motor power connector, please do so according to the following procedure which correlates to the 13 steps in the diagram that follows this procedure.

Step	Action
1	Carefully remove about 70 mm of the outer jacket while taking care not to damage the braided shield.
2	Push the grommet over the cable until the end is flush with the jacket.
3	Push the outer braided shield back over the grommet.
4	Position the shielding for the brake wires over the outer shielding braid and ensure good electrical contact.
5	Push the filling wires and protective cloth back over the shielding.
6	Push the shrink tubing (30mm long) over the shielding and leave about 15mm exposed.
7	Use a hot-air blower to shrink the tubing then shorten the wires for U, V, W to 45mm and those for BR+, BR- to 55mm.
8	Carefully remove about 10mm of the ends of the wires while taking care not to damage the copper strands.
9	Attach crimp ferrules to the ends of the wires
10	Place the shielding plate in the connector housing and push the contact tabs into the PE terminal clamp of the connector.
11	Attach the cable with the strain relief.
12	Ensure the clamping loop of the strain relief sits properly on the shielding braid.
13	Push the wire ferrules into the corresponding terminals in the connector and tighten.

---

*Continued on next page*

## Wiring the Motor Power Connector (Drive end), continued

### Motor Power Connector (Drive end) Diagram (excluded BPH055)

The following diagram shows the 13 steps required to wire a motor power connector (excluded BPH055).

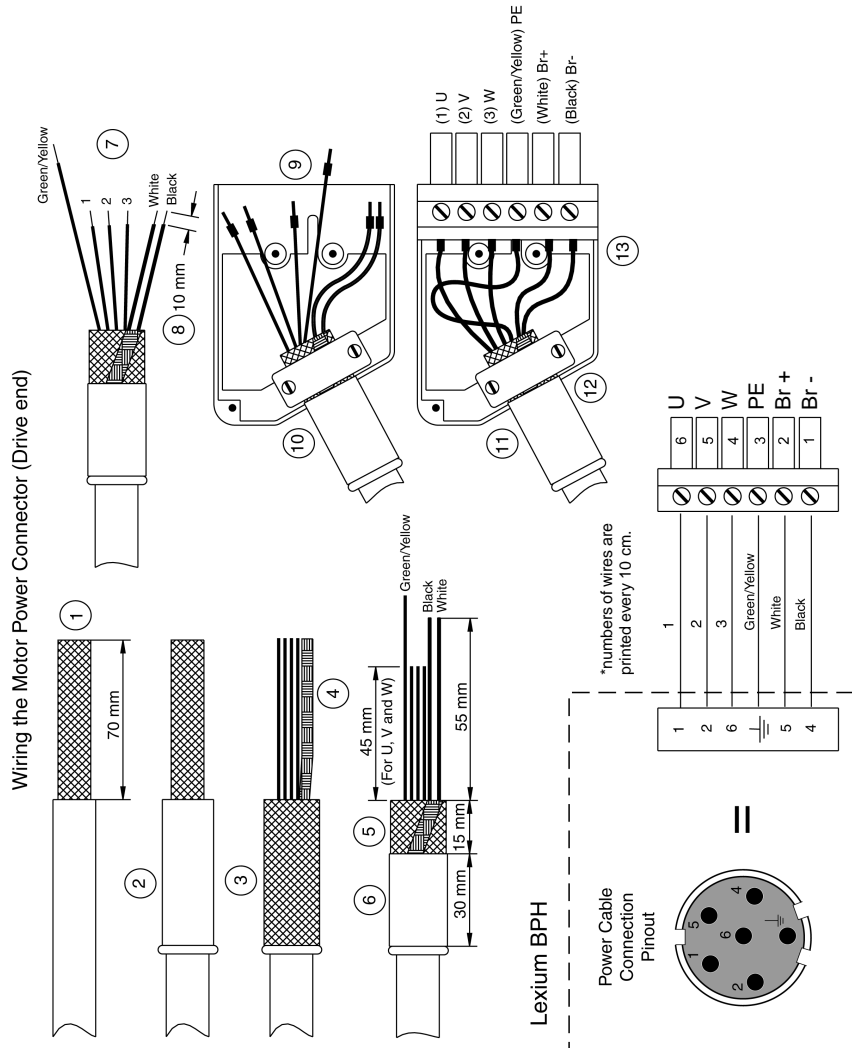

## Wiring the Motor Power Connector (Drive end), continued

### BPH055 Motor Power Connector (Drive end) Diagram

The following diagram shows the 13 steps required to wire a BPH055 motor power connector.

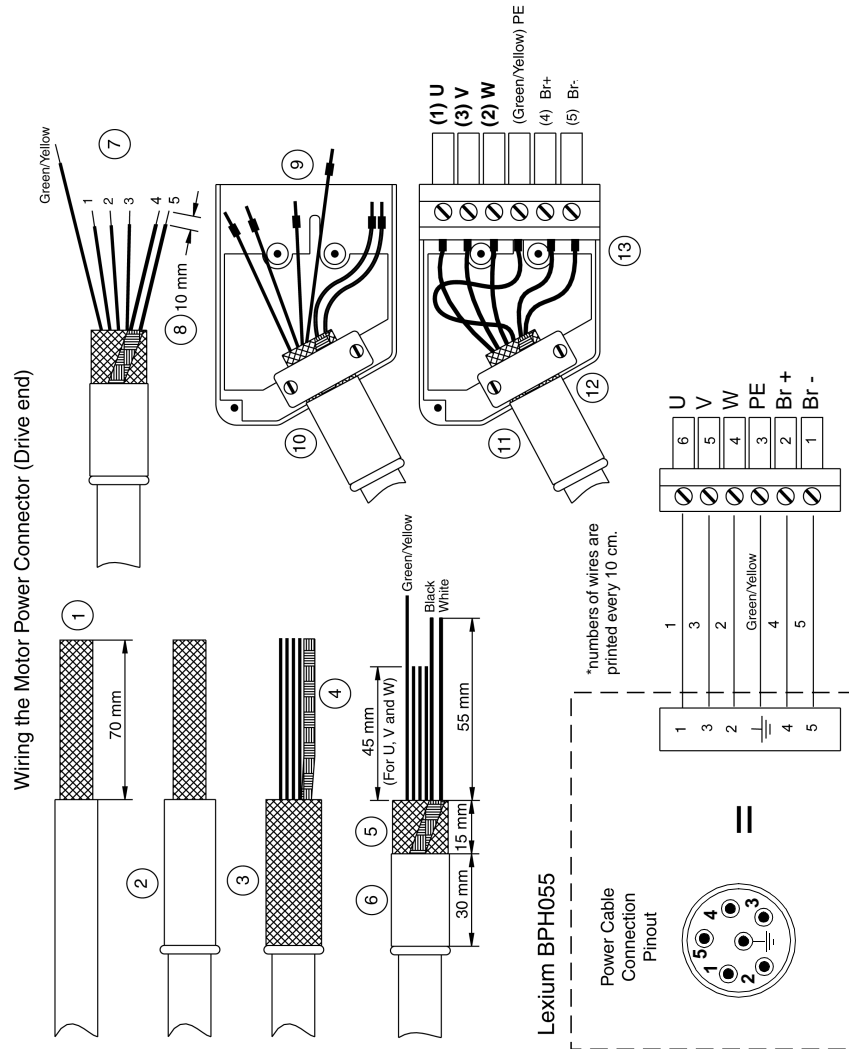

---

## Serial Communication Interface Connection (X6)

---

### Serial Communication Interface Cable Connectors

The following diagram details the null modem connection between the drive and a PC.

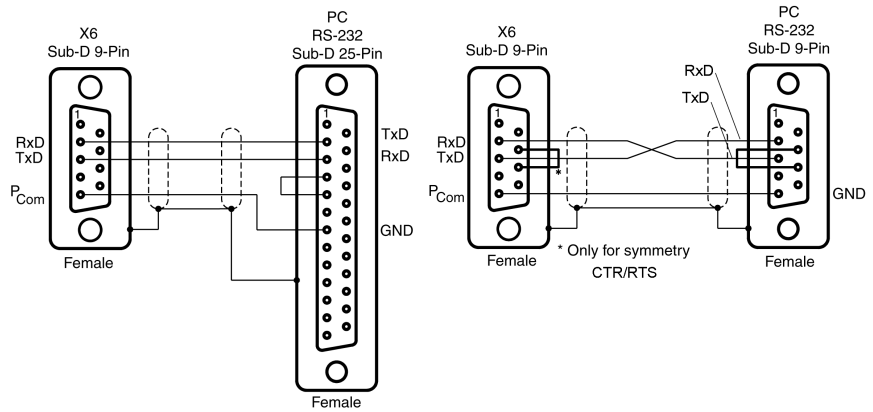

---



---

# Servo Loop Diagrams



# D

---

## At a Glance

### What's in this Appendix

This appendix illustrates several servo loops within a 17S SERCOS drive system.

Topic	Page
17S current controller overview	118
17S velocity controller loop	119
17S position controller loop	120

---

---

## 17S Current Controller Overview

---

### 17S Current Controller Diagram

The following diagram shows an overview of the 17S current controller servo loop.

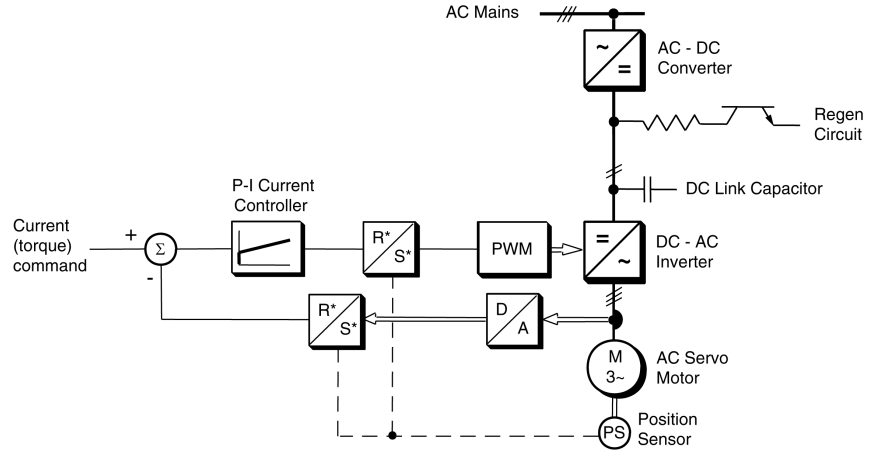

\* R = Rotor oriented ( $I_d, I_q$ ); S = Stator oriented ( $I_a, I_b, I_c$ )

---

## 17S Velocity Controller Loop

---

### 17S Velocity Controller Loop Diagram

The following diagram shows a 17S velocity controller servo loop.

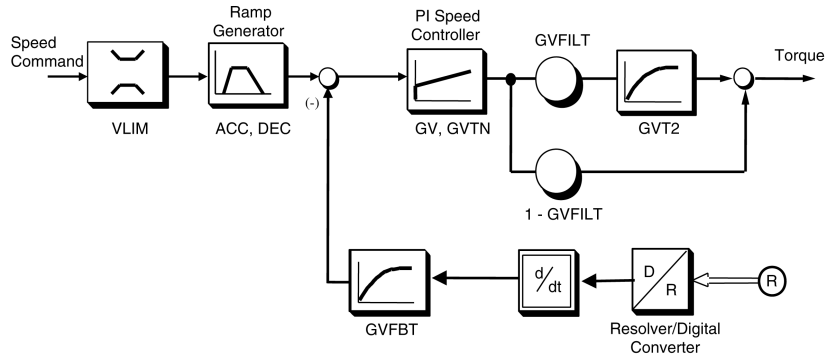

**Note:** Parameter designations correlate to terms used in the UniLink software.



---

# Optional External Regen Resistor Sizing

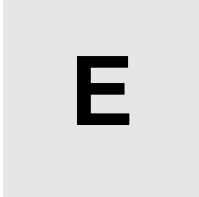

---

## At a Glance

### What's in this Appendix

This appendix contains descriptions and procedures for calculating the power dissipation requirements for the optional external Regen resistor.

This appendix presents the following topics.

Topic	Page
Determining external Regen resistor size	123
Example Regen resistor power dissipation calculation	125

---

*Continued on next page*

---

## At a Glance, continued

---

### Overview

When the drive is braking or decelerating a moving load, the kinetic energy of the load must be absorbed by the drive. As the drive decelerates the load, this energy charges the DC link capacitors to successively higher voltages. To prevent damage to the internal electronics, a shunt regulator circuit will apply the Regen resistor across the capacitors when the voltage rises to a set voltage level (determined by the “Mains Voltage” parameter). This dissipates the remaining energy as heat in the Regen resistor. The energy dissipated by the Regen resistor must be calculated in order to determine the proper power rating of the resistor.

---

### Determining When Energy Is Absorbed

To determine when the drive is absorbing energy, examine the motion profile (that is, a graphical plot) of axis speed and torque applied to the motor. Whenever the sign (+ or -) of the torque applied to the motor is opposite that of the speed, the drive is absorbing energy. This typically happens when the drive is decelerating the motor, the motor is controlling tension in a web application, or the motor is lowering a mass in a vertical axis.

---

## Determining Optional External Regen Resistor Size

### Power Dissipation Calculation Procedure

The following is the procedure for calculating the power dissipated by the Regen resistor in a simple system wherein friction is negligible. Ignoring friction in the following calculations gives worst case results since friction will absorb a portion of the energy during deceleration. An example of each step in this procedure is provided later in this chapter.

Step	Action
1	Plot speed versus time and torque versus time for the entire move cycle. (Magnitude of the torque is not required; only the direction is required.)
2	Identify each section of the plot where the drive is decelerating the load or where speed and torque have opposite signs.
3	Calculate the energy returned to the drive in each deceleration using the formula $E = \frac{1}{2} J_t \omega^2$ Where E = Energy in joules $J_t$ = Total system inertia, including motor, in $\text{kg(m}^2\text{)}$ $\omega$ = Speed at start of deceleration in radians per second ( $\omega = 2 \pi \text{ RPM} / 60$ )
4	Compare the energy in each deceleration with the energy required to turn on the Regen circuit. (See Drive Energy Absorption Capability table.) If the energy is less than that listed in the table, disregard that deceleration for the remainder of the calculations.
5	Calculate the energy dissipated by the Regen resistor by subtracting the energy listed in the table from the energy of the deceleration. $E_{\text{dissipated}} = E_{\text{generated}} - E_{\text{absorbed by capacitors}}$
6	Calculate the pulse power of each deceleration by dividing the dissipated energy by the time of the deceleration. $P_{\text{pulse}} = E_{\text{dissipated}} / T_{\text{decel (seconds)}}$
7	Calculate the continuous power dissipated by the Regen resistor by totaling all the dissipated energy and dividing it by the total cycle time. $P_{\text{continuous}} = (E1_{\text{dissipated}} + E2_{\text{dissipated}} + \dots + E_n_{\text{dissipated}}) / T_{\text{total cycle (seconds)}}$

*Continued on next page*

---

## Determining External Regen Resistor Size, continued

---

### Power Dissipation Calculation Procedure, continued

Step	Action
8	Compare the pulse power and the continuous power calculated with the ratings of the internal Regen resistor in the drive. If either one is greater then an optional external Regen resistor must be chosen and installed. (See the Parts List appendix for a list of the available optional external Regen resistors.)

---

### Drive Energy Absorption Capability

The drive energy absorption capability values (in joules) that are needed during the sizing calculations are provided in the following table.

Drive Energy Absorption Capability (joules)				
Line Voltage		230 VAC	400 VAC	480 VAC
Drive Model Number	MHDS1004N00 MHDS1008N00 MHDS1017N00 MHDS1028N00	5	19	23
	MHDS1056N00	10	38	47



**Note:** Multiple drives can be interconnected via the DC-Link. When this is done, the energy absorption capability of the drives and the continuous power ratings of the Regen resistors are additive. The energy absorbed by the drives must be calculated by superimposing all the time speed plots and calculating the energy generated by each axis. (For calculating the power in complex multi-drive applications contact Schneider Electric for assistance.)

---



---

## Example Regen Resistor Power Dissipation Calculation

---

### Example Motor and Drive Specifications

The following is an example application of each step in the power dissipation calculation procedure using the motor, drive and input power specifications identified below. Refer to the power dissipation calculation procedure presented earlier in this chapter.

- Motor = BPH1423N with brake

$$\text{Total Inertia (J}_T\text{)} = J_M + J_B + J_L = 0.002 + 0.001 + 0.007 = 0.01 \text{ kgm}^2$$

where:

$$\text{Motor inertia (J}_M\text{)} = 0.002 \text{ kg(m}^2\text{)}$$

$$\text{Brake inertia (J}_B\text{)} = 0.001 \text{ kg(m}^2\text{)}$$

$$\text{Load inertia (J}_L\text{)} = 0.007 \text{ kg(m}^2\text{)}$$

- Drive = MHDS1028N00
- Line Voltage = 480 Vac

---

*Continued on next page*

---

## Example Regen Resistor Power Dissipation Calculation, continued

---

**Example Step 1** Plot speed versus time and torque versus time for the entire move cycle.

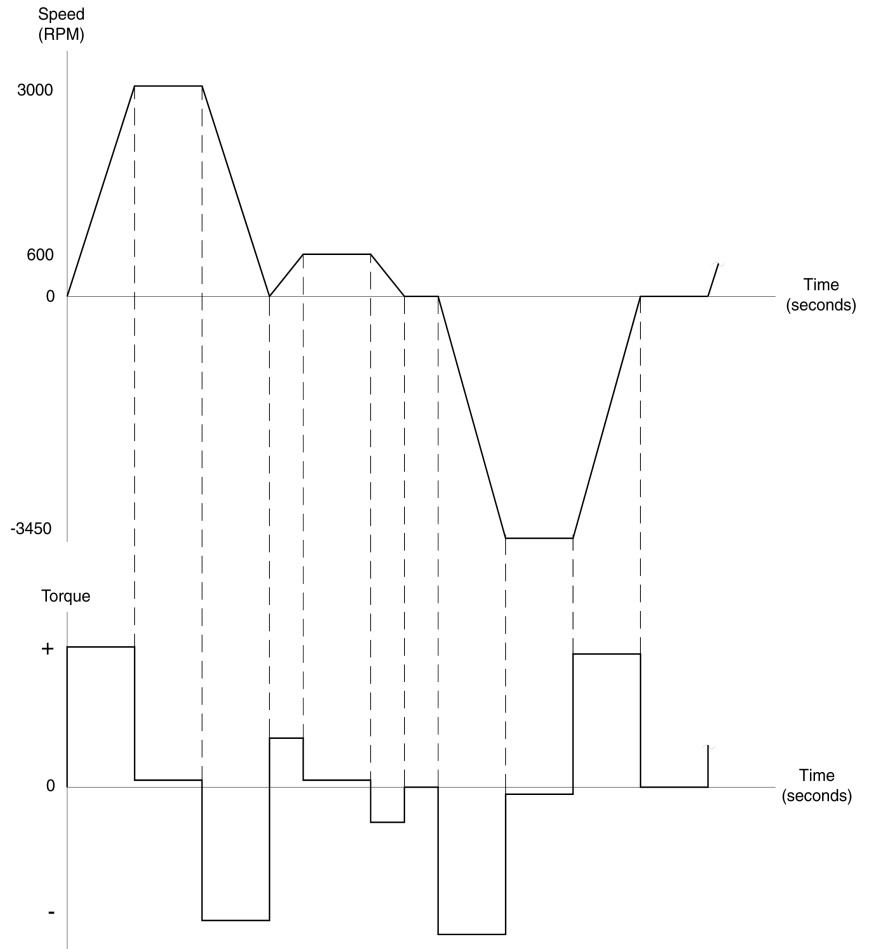

*Continued on next page*

---

## Example Regen Resistor Power Dissipation Calculation, continued

---

**Example Step 2** Identify each deceleration of the plot where the drive is decelerating the load.

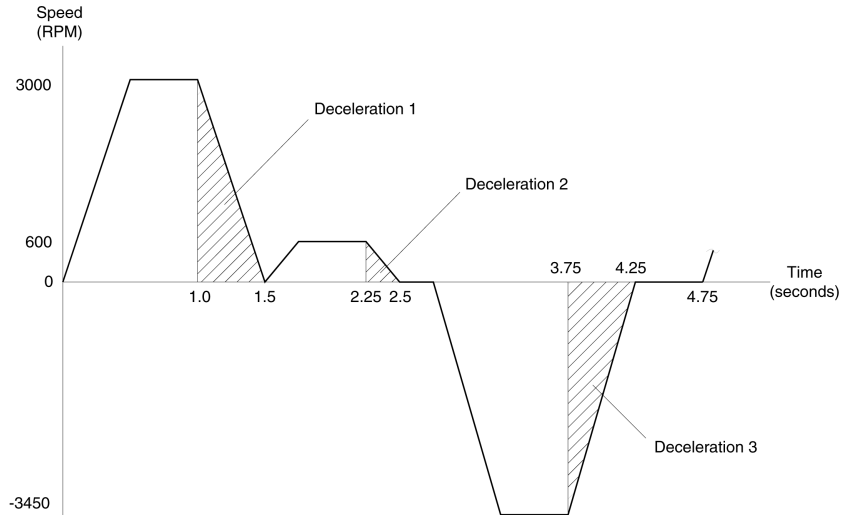

---

**Example Step 3** Calculate the energy returned to the drive in each deceleration as follows:

Deceleration 1

$$\omega = 2 \pi 3000\text{RPM} / 60 = 314 \text{ radians/sec}$$
$$E = \frac{1}{2} 0.01\text{kgm}^2 (314 \text{ radians/sec})^2 = 493 \text{ joules}$$

Deceleration 2

$$\omega = 2 \pi 600\text{RPM} / 60 = 63 \text{ radians/sec}$$
$$E = \frac{1}{2} 0.01\text{kgm}^2 (63 \text{ radians/sec})^2 = 20 \text{ joules}$$

Deceleration 3

$$\omega = 2 \pi 3450\text{RPM} / 60 = 361 \text{ radians/sec}$$
$$E = \frac{1}{2} 0.01\text{kgm}^2 (361 \text{ radians/sec})^2 = 652 \text{ joules}$$

---

*Continued on next page*

---

## Example Regen Resistor Power Dissipation Calculation, continued

---

**Example Step 4** Compare the energy in each deceleration with the energy required to turn on the Regen circuit (that is, the energy absorbed by the internal capacitors).

As specified in the Drive Energy Absorption Capability table, the MHDS1028N00 drive at 480 Vac can absorb 23 joules without turning on the Regen resistor circuit.

Deceleration 1: 493 joules > 23 joules

Deceleration 2: 20 joules < 23 joules (disregard this segment in the remaining steps)

Deceleration 3: 652 joules > 23 joules

---

**Example Step 5** Calculate dissipated energy as follows:

Deceleration 1:  $E = 493 - 23 = 470$  joules

Deceleration 3:  $E = 652 - 23 = 629$  joules

---

**Example Step 6** Calculate the pulse power as follows:

Deceleration 1:  $P_{\text{pulse}} = 470 \text{ joules} / 0.5 \text{ seconds} = 940$  watts

Deceleration 3:  $P_{\text{pulse}} = 629 \text{ joules} / 0.5 \text{ seconds} = 1258$  watts

---

**Example Step 7** Calculate continuous power as follows:

$P_{\text{continuous}} = (470 \text{ joules} + 629 \text{ joules}) / 4.75 \text{ seconds} = 231$  watts

---

*Continued on next page*

---

## Example Regen Resistor Power Dissipation Calculation, continued

---

**Example Step 8** Compare the ratings as follows:

Internal Regen resistor ratings of the MHDS1028N00:

$$P_{\text{pulse}} = 21 \text{ kW}$$

$$P_{\text{continuous}} = 200\text{W}$$

Deceleration 1:  $P_{\text{pulse}} = 940\text{W} < 21 \text{ kW rating}$

Deceleration 2:  $P_{\text{pulse}} = 1258\text{W} < 21 \text{ kW rating}$

$$P_{\text{continuous}} = 231\text{W} > 200\text{W}$$

Requires an optional external Regen resistor be used. Select the 250W optional external Regen resistor or modify the profile to reduce the continuous power dissipated.

---

---

---

# Index



## A

AC mains power supply, connection, 49  
acronyms and abbreviations, 12  
additional safety guidelines, 9  
air flow, 36  
analog  
    input connection, 63  
    input specifications, 98  
auxiliary encoder interface, 60

## B

bias  
    input specifications, 89  
    power, 28  
    supply, connection, 49  
BPH055 Motor Power Connector (Drive end) Diagram, 114  
brake output specifications, 97

## C

cable  
    separation, 36  
    shield connections, 47, 48  
cables  
    parts list, 104  
current controller servo loop, 118

## D

DC Link capacitor reconditioning, 29  
default settings, 31  
determining external regen resistor size, 123  
digital control, 25  
digital inputs and outputs connection, 64  
dimensions, physical, 44, 48, 55  
discrete  
    input specifications, 96  
    output specifications, 96  
document scope, 1  
drive dimensions, 37  
drive energy absorption capability, 124  
drive implementation, 16  
drive models, 16, 102  
drive mounting and physical dimensions, 37, 38  
drives available, 16  
drives, family, 18  
drives, front view, 19  
drive-to-motor cables, 104

## E

earth connections, 36  
EC directive compliance, 10  
electric shock hazards, 6  
electrical considerations, 17  
electrical specifications, 87, 91  
    regen resistor, 92  
    signal, 93

electrostatic components precaution, 8  
emergency stop strategies, 69  
EMI suppression, 28  
encoder  
    input connection, 59  
    input specifications, 94  
    output cables, 104  
    output specifications, 94, 95  
environmental and mechanical specifications, 85  
environmental specifications, 85  
equipment available, 20  
equipment supplied, 20  
error identification and description, 77  
error messages, 77  
European directives and standards, 10  
example motor and drive specifications, 125  
External 24Vdc supply, 103  
external fuse specifications, 89  
external Regen resistor mounting and physical dimensions, 39  
external regen resistor, connections, 51

## F

fault relay and digital I/O, connection, 64  
fault relay output specifications, 97  
fiber optic cables parts table, 105  
front panel controls and indicators, 73

## G

general characteristics, 28  
grounding, 43

## H

hazards and warnings, 6

## I

installation considerations, 36  
installation safety precautions, 34  
internal electronics, block diagram, 27

internal power, 29  
internal power dissipation specifications, 91

## K

keypad operation, 73

## L

LED display, 30, 73  
Lexium 17S, 44, 46  
    connection diagram, 45  
    drives, 102  
    system configuration, diagram, 21  
Lexium BPH resolver connection (excluded BPH055), 57  
Lexium BPH055 resolver connection, 58  
line input specifications, 88

## M

mechanical specifications, 86  
models, drive, 16, 102  
motor  
    output specifications, 90  
    overtemperature specifications, 93  
    to drive cables, 104  
motor choke mounting and dimensions, 40  
motor power connector wiring diagram (excluded BPH055), 113

## O

optional external Regen resistor assembly dimensions, 39  
optional motor choke, 107  
optional motor choke assembly dimensions, 40  
output cables, 104  
overcurrent protection, 36  
overview  
    drive models, 16, 102



## P

- parts list
  - cables, 104
  - overview, 101
  - regen resistor assemblies, 106
  - spare parts, 107, 108
- performance specifications table, 84
- physical dimensions, 37
- pin assignments, 46
- position servo loop, 120
- power
  - dissipation calculation, 123
  - electrical specifications, 88
  - supply overcurrent protection, 36
  - wiring, 49
- power-on and power-off characteristics, 68
- pre-programmed functions, use, 65
- primary power, 28
- problems, possible causes and corrective actions, 81
- products, introduction, 15

## Q

- qualified personnel, 9
- quick start procedure, 71

## R

- regen circuit functional description, 51
- regen circuit specifications, 92
- regen resistor
  - assembly parts list, 106
  - determining when energy is absorbed, 122
  - power dissipation calculation, example, 125
- related documentation, 5
- resolver, input specifications, 93
- RS232 interface cable connectors, 115
- RS-232 null modem type communication, connection diagram, 66
- RS-232 serial communications cable, 104

## S

- safe electrical separation, 29
- SERCOS
  - communication LED indicators, 74
  - fiber-optic transmit and receive connectors, 22
  - network overview, 22
  - Network Ring Configuration, 23
  - standard, 11
- serial communications specifications table, 98
- serial communications, connection, 66
- serial power, connections, 50
- servo loops
  - current controller, 118
  - position controller, 120
  - velocity controller, 119
- servo motor (with brake) (excluded BPH055), connection, 52
- servo motor (with Optional Dynamic Brake Resistors and Contactor), connection, 54
- servo motor BPH 055 (with options), connection, 53
- servo motor holding-brake control, 55
- servo motors, types, 16
- setting parameters, 31
- signal wiring, 57
- software setup, 31
- spare parts, 107, 108

specifications

- analog input, 98
- bias input, 89
- brake output, 97
- discrete input, 96
- discrete output, 96
- electrical, 87
- encoder input, 94
- encoder output, 94, 95
- environmental, 85
- external fuse, 89
- fault relay output, 97
- internal power dissipation, 91
- line input, 88
- mechanical, 86
- motor output, 90
- motor overtemperature, 93
- power electrical, 88
- resolver input, 93

stop function, 69

Sub-D connector wiring diagram, 111

warning messages, 76

who should use this guide, 2

wire specifications, 99

wiring

connections, 44

wiring a Sub-D connector with shielding, 110

wiring and I/O, initial considerations, 43

wiring connections, 44

wiring overview, 44

wiring the motor power connector, 112

wiring the Sub-D connector, 110

## T

thermal hazard, 7

troubleshooting, 81

## U

UL 508C, 11

UL 840, 11

UL and cUL compliance, 11

UniLink commissioning software, 4

usability enhancements, 26

usability features, 25

user guide organization, 2

## V

velocity servo loop, 119

verifying system operation, 71

## W

warning identification and description, 76